

SOLARMOUNT™

Flush Mounting SMR Rail Sets with CT Top Mounting Clamps

These instructions cover flush mounting on a pitched roof. *If your installation also includes tilt legs (for roof or ground), see instructions shipped with the leg kit.*

Installer responsibility

Please read and understand these instructions completely before installing your SolarMount.

The installer is solely responsible for:

- complying with all applicable building codes, which supercede these instructions;
- ensuring that the roof and its rafters or other support can support the PV array;
- ensuring that lag bolts (if used) have adequate pullout strength;
- maintaining the waterproof integrity of the roof; and
- installing all electrical aspects of the PV array.

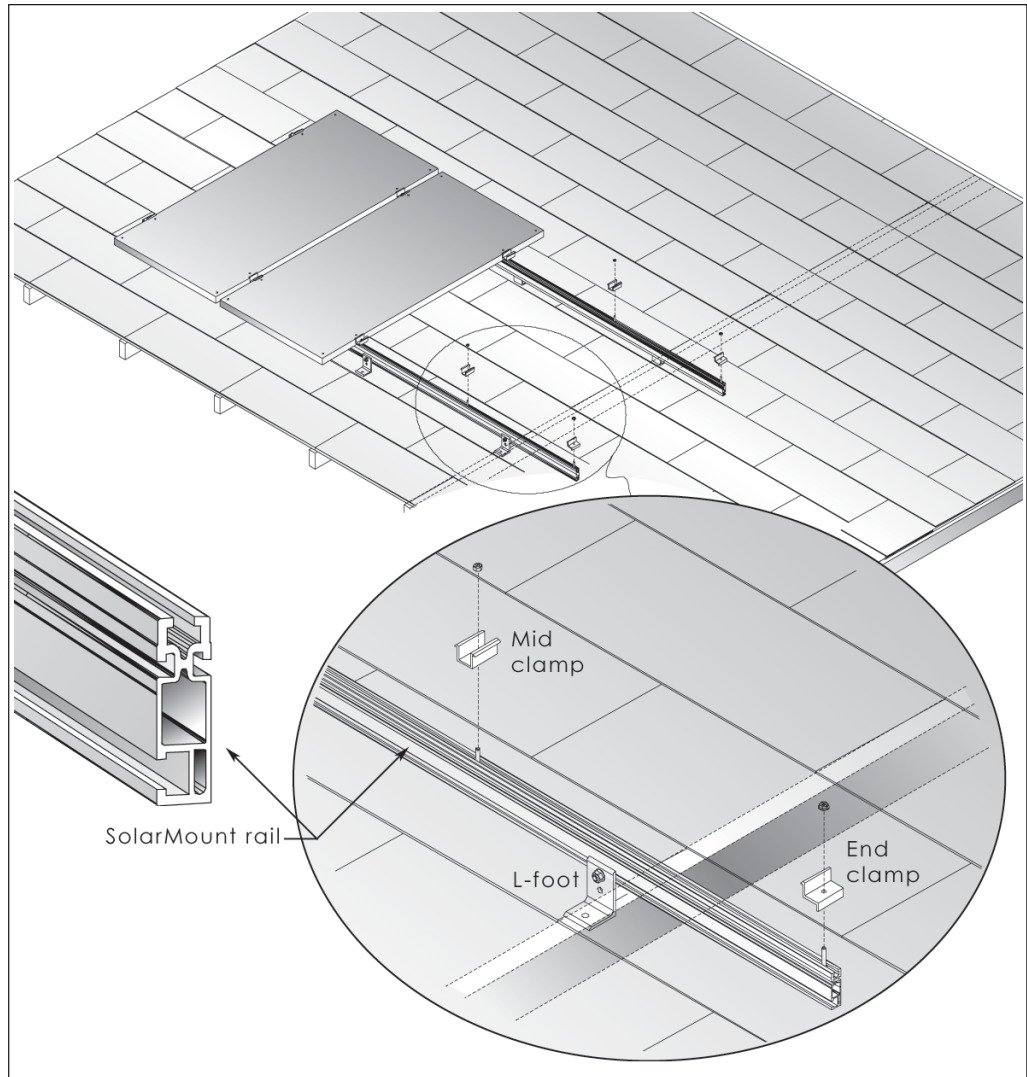

Figure 1. Exploded view of low-profile mode installation with L-feet

Contents

Parts quantities	2	Laying out standoffs	4
Tools and torque	2	Installing standoffs	4
Laying out the installation area	2	Installing SolarMount rails	5
Laying out L-feet	3	Installing the modules	6
Installing L-feet	3		

Caution: Stainless steel nuts and bolts can seize up, a process called galling. To significantly reduce the likelihood of galling, a packet of SAF-T-EZE anti-seize lubricant has been included with your rack for use on stainless steel hardware.

Part quantities

SMR Series Rail Sets (model no. = rail length in inches)

	Rails	L-feet	3/8" footing bolts	3/8" flange nuts
SMR48 thru 106	2	4	4	4
SMR120 thru 180	2	6	6	6
SMR192 thru 216	2	8	8	8

CT Series Clamp Sets

(model no. = modules accommodated)

	End clamps	Mid clamps	1/4" module clamp bolts	1/4" x 5/8" safety bolts	1/4" flange nuts
CT2	4	2	6	2	8
CT3	4	4	8	2	10
CT4	4	6	10	2	12
CT5	4	8	12	2	14
CT6	4	10	14	2	16
CT7	4	12	16	2	18
CT8	4	14	18	2	20

Tools and torque

	Wrench size	Recommended torque (ft-lbs)
1/4" hardware	7/16"	15
3/8" hardware	9/16"	30

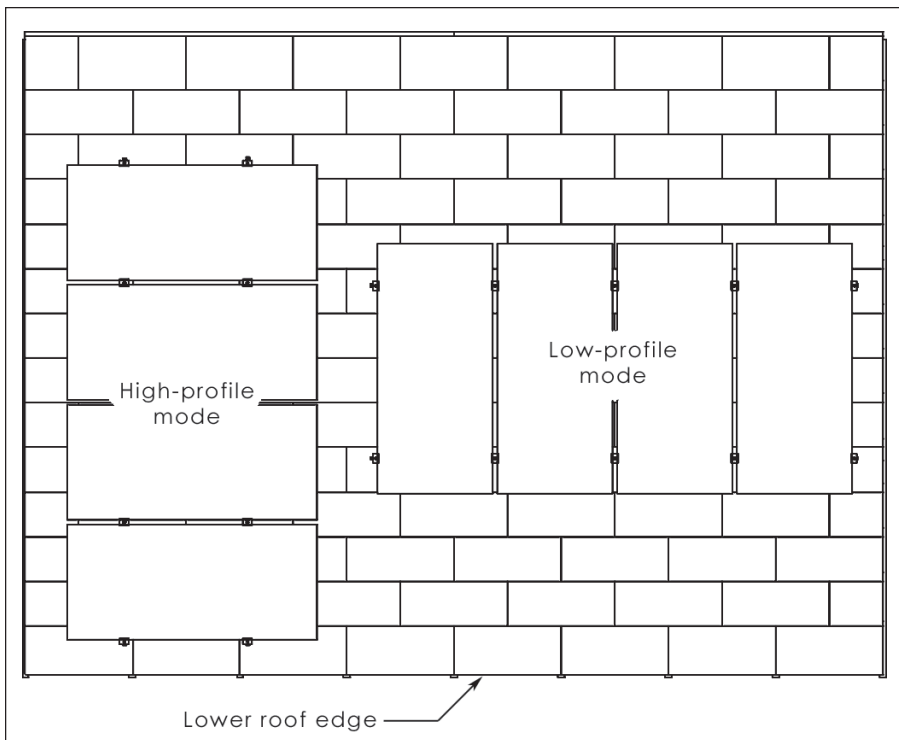

Figure 2. Rails may be placed parallel or perpendicular to rafters.

Laying out the installation area

The installation can be laid out with rails parallel to the rafters (high-profile mode) or perpendicular to the rafters (low-profile mode). Note that SolarMount rails make excellent straight edges for doing layouts.

Center the installation area over the rafters as much as possible.

Leave enough room to safely move around the array during installation.

The *width* of the installation area is equal to the *length* of one module.

The *length* of the installation area is equal to:

- the total *width* of the modules,
- *plus* 1 inch for each space between modules (for mid-clamp),
- *plus* 3 inches (1-1/2 inches for each set of end clamps).

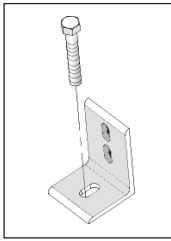

Figure 3

Laying out L-feet

L-feet (Fig. 3) are used for installation through existing roofing material, such as asphalt shingles or sheet metal.

Use Figure 4 or Figure 5 below to locate and mark the L-foot lag bolt holes within the installation area.

Consult UniRac's Technical Bulletin 103.1, *Code-Compliant SolarMount Installation* (January 2003), to determine foot spacing that will meet the Uniform Building Code. It can be downloaded at www.unirac.com.

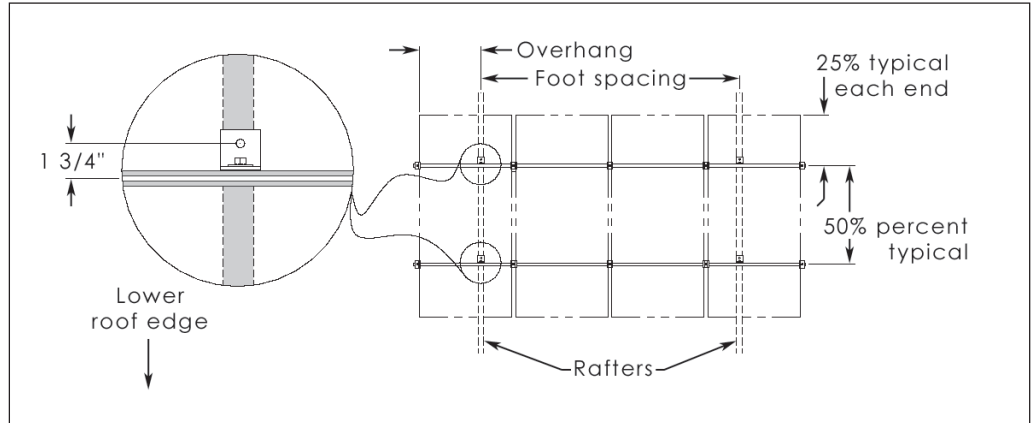

Figure 4. Low-profile layout

When determining the distance between the rails in high-profile mode, keep in mind that the center of each rail will be offset from the L-foot lag bolt holes by 1 3/4 inches.

If multiple high-profile rows are to be installed adjacent to one another, it will not be possible for each row to be centered above the rafters. Adjust as needed, following the guidelines in Figure 5 as closely as possible.

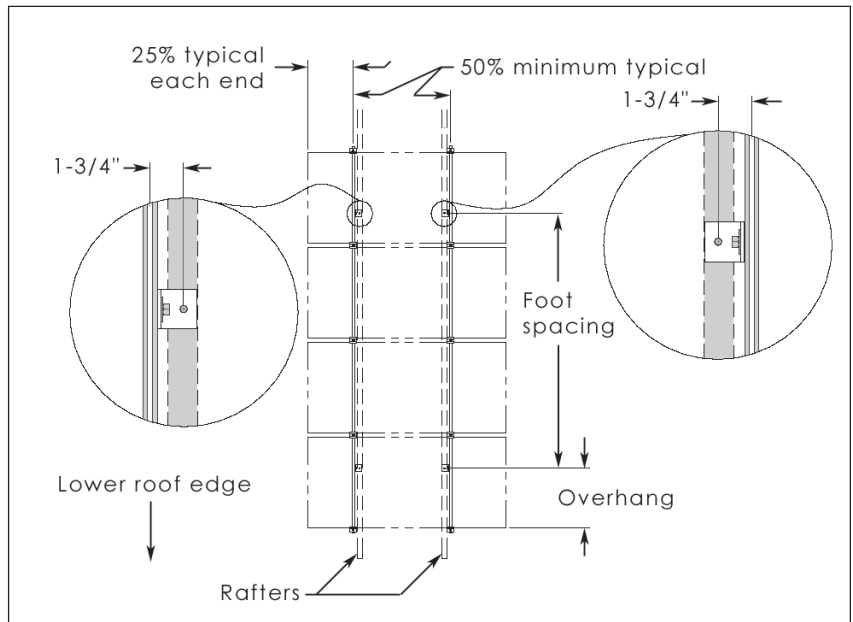

Figure 5. High-profile layout

Installing L-feet

Drill pilot holes through the roof into the center of the rafter at each L-foot lag bolt hole location.

Consult Technical Bulletin 103.1 for guidelines to determine the lag bolts that you must use to meet building code wind load requirements for your installation. Lag bolts are not provided with SolarMount rail sets.

Squirt sealant into the hole, and on the shafts of the lag bolts. Seal the underside of the L-foot with a suitable weatherproof sealant.

Securely fasten the L-feet to the roof with the lag bolts. Ensure that the L-feet face as shown in Figure 4 or Figure 5, as appropriate.

Laying out standoffs

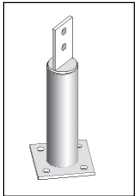

Figure 6

Standoffs (Fig. 6) are used for flashed installations, such as those with tile and shake shingles. Use Figure 7 or Figure 8 to locate and mark the standoff lag bolt holes within the installation area. Consult UniRac’s Technical Bulletin 103.1, *Code-Compliant SolarMount Installation* (January 2003), to determine foot spacing that will meet the Uniform Building Code. It can be downloaded at www.unirac.com.

Remove the tile or shake underneath each standoff location, exposing the roofing underlayment. Ensure that the standoff base lies flat on the underlayment, but remove no more material than required for the flashings to be installed properly.

Use the standoff base as a template to mark lag bolt hole locations on underlayment above the

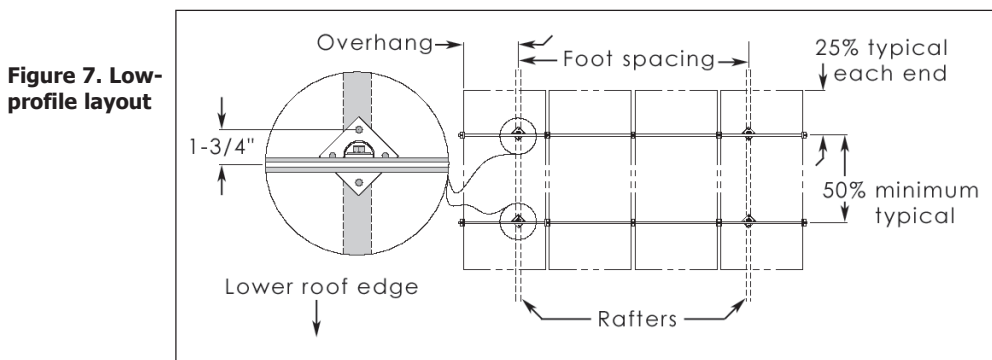

Figure 7. Low-profile layout

When determining the distance between the rails in high-profile mode, keep in mind that the center of each rail will be offset from the standoff lag bolt holes by 7/16 of an inch.

If multiple high-profile rows are to be installed adjacent to each other, it will not be possible for each row to be centered above the rafters. Adjust as needed following the guidelines in Figure 8 as closely as possible.

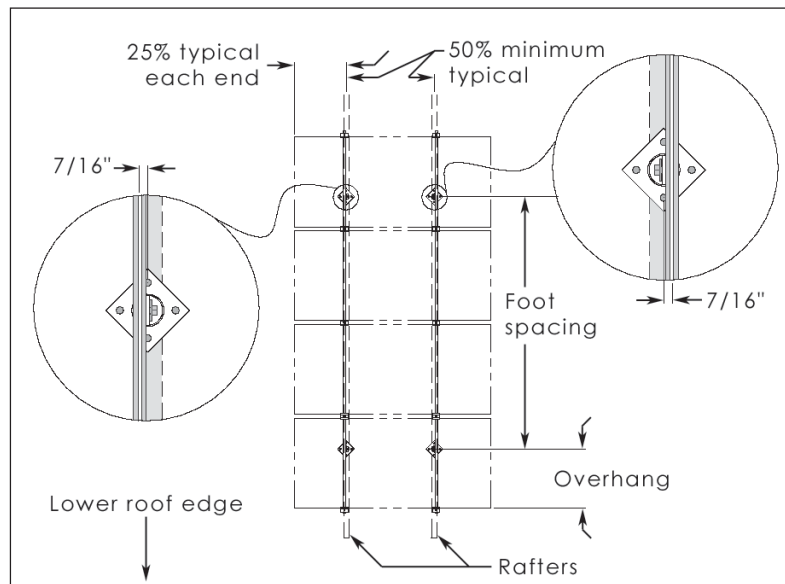

Figure 8. High-profile layout

Installing standoffs

Drill 3/16-inch pilot holes through the underlayment into the center of the rafters at each standoff location. Securely fasten standoffs to the rafters with the lag bolts provided with the standoffs. Ensure that the standoffs face as shown in Figure 4 or Figure 5, as appropriate.

SolarMount standoffs are designed for easiest installation with Oatey® 1¼”–1½” No-Calk® flashings. They can be obtained at most plumbing and roofing supply companies.

Install and seal flashings and standoffs using standard building practices.

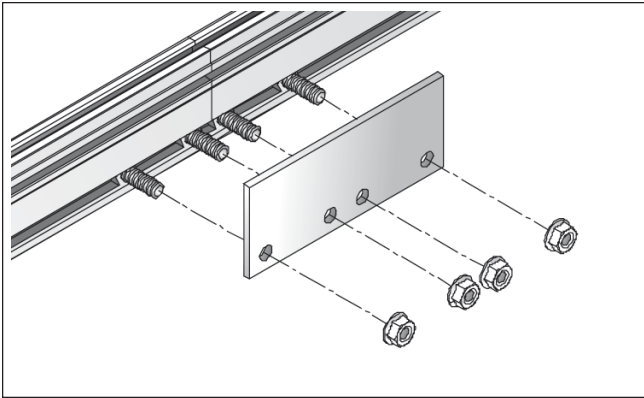

Figure 9. Rail Splice

Installing SolarMount rails

Keep rail slots free of roofing grit or other debris. *Foreign matter will cause bolts to bind as they slide in the slots.*

Installing Splices. If your installation uses SolarMount splices, attach the rails together (Fig. 9) before mounting the rails to the footings.

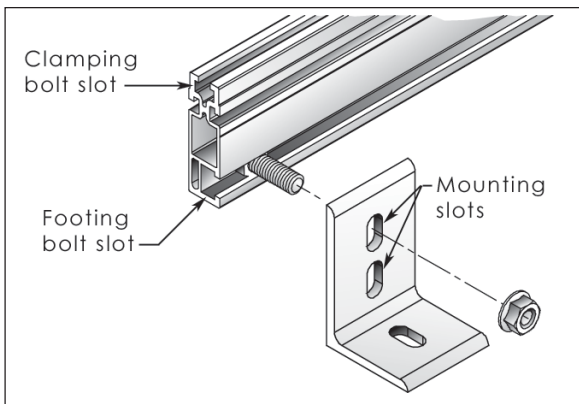

Figure 10. Foot-to-rail splice attachment

Mounting Rails on Footings. Rails may be attached to either of two mounting holes in the footings (Fig. 10). Mount in the lower hole for a low profile, more aesthetically pleasing installation. Mount in the upper hole for a higher profile, which will maximize airflow under the modules. This will cool them more and may enhance performance in hotter climates.

Slide the 3/8-inch mounting bolts into the footing bolt slots. Loosely attach the rails to the footings with the flange nuts.

Ensure that the rails are oriented to the footings as shown in Figure 4, 5, 7, or 8, whichever is appropriate.

Aligning the Rail Ends.

Align one pair of rail ends to the edge of the installation area (Fig. 11 or Fig. 12).

The opposite pair of rail ends will overhang the side of the installation area. Do not trim them off until the installation is complete.

In low-profile mode (Fig. 11), either end of the rails can be aligned, but the first module must be installed at the aligned end.

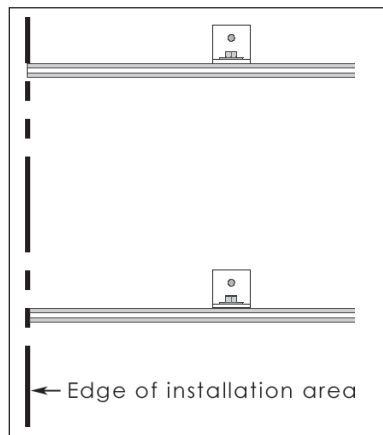

Figure 11. Low-profile mode

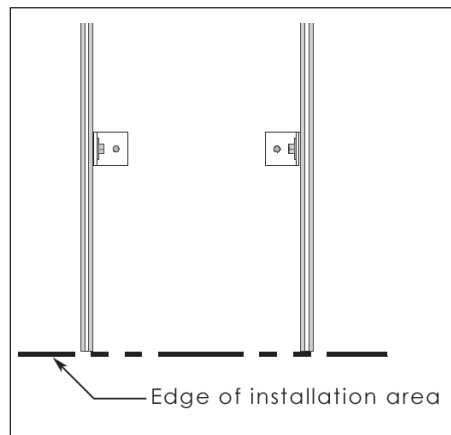

Figure 12. High-profile mode

For the safest high-profile installation (Fig. 12), the aligned end of the rails must face the lower edge of the roof.

Securely tighten the flange nuts on the mounting bolts after alignment is complete (28–32 ft lbs).

Installing the modules

Prewiring Modules. If modules are the Plug and Play type, no prewiring is required, and you can proceed directly to "Installing the First Module" below.

If modules have standard J-boxes, each module should be prewired with one end of the intermodule cable for ease of installation. For safety reasons, module prewiring should not be performed on the roof.

Leave covers off J-boxes. They will be installed when the modules are installed on the rails.

Installing the First Module. *In high-profile installations, the safety bolt and flange nut must be fastened to the module bolt slot at the aligned (lower) end of each rail. It will prevent the lower end clamps and clamping bolts from sliding out of the rail slot during installation.*

Slide half of the ¼-inch clamping bolts onto each rail, spacing them evenly along the rails.

Drop end clamps over the clamping bolts at the aligned end of each rail. Loosely attach them with flange nuts. Allow half an inch between the rail ends and the end clamps (Fig.13). If there is a return cable to the inverter, connect it to the first module. Close the J-box cover.

Slide the first module under the end clamps. Center and align as needed. Securely tighten the flange nuts onto the end clamps (15 ft lbs).

Installing the Other Modules. Slide the next clamping bolt on each rail up to the first module. Drop mid-clamps over these clamping bolts and loosely attach them with flange nuts.

Lay the second module face down (glass to glass) on the first module. Connect intermodule cable to the second module and close the J-box cover.

Turn the second module face up (Fig. 14). Slide it under the mid-clamps. Align it and securely tighten the flange nuts onto the mid-clamps between modules (Fig. 15).

For a neat installation, fasten cable clamps to rails with self-tapping screws.

Repeat the procedure until all modules are installed. Attach the outside edge of the last module to the rail with end clamps.

Trim off any excess rail, being careful not to cut into the roof. Allow half an inch between the end clamp and the end of the rail (Fig. 13).

Check that all flange nuts on clamping bolts are securely fastened.

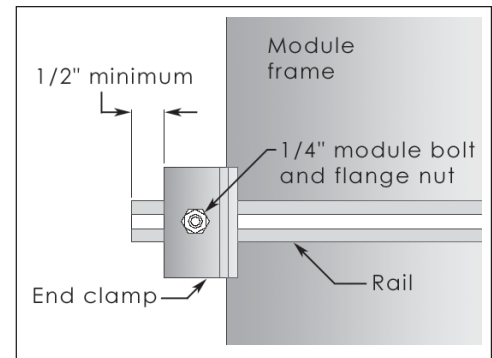

Figure 13

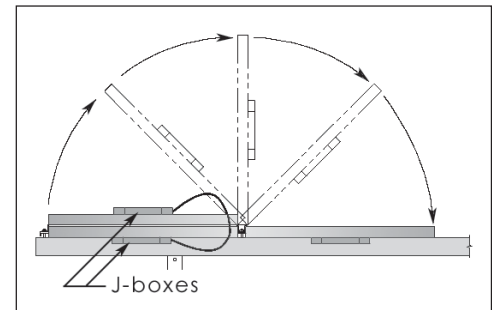

Figure 14

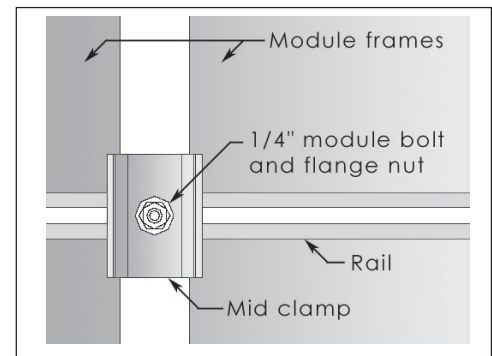

Figure 15

10 Year Limited Warranty

UniRac, Inc., warrants to the original owner at the original installation site that the SolarMount PV Module Mounting System (the "Product") shall be free from defects in material and workmanship for a period of ten (10) years from the earlier of 1) the date the installation is complete, or 2) 30 days after the purchase of the Product by the original owner. This warranty does not cover damage to the Product that occurs during shipment, or prior to installation.

If within such period the Product shall be reasonably proven to be defective, then UniRac shall repair or replace the defective Product, or part thereof, at UniRac's sole option. Such repair or replacement shall fulfill all UniRac's liability with respect to this warranty.

This warranty shall be void if installation of the Product is not performed in accordance with UniRac's Assembly Instructions for the Product, or if the Product has been modified, repaired, or reworked in a manner not authorized by UniRac in writing, or if the Product is installed in an environment for which it was not designed. UniRac shall not be liable for consequential, contingent, or incidental damages arising out of the use of the Product.

Pub 030110-1ii
©2003 by UniRac, Inc.
All rights reserved.

UNI-RAC® THE NEW STANDARD IN PV MODULE RACKS™

UNI-RAC, INC., 3201 UNIVERSITY BLVD SE, SUITE 110, ALBUQUERQUE, NM 87106-5635 USA
505.242.6411 FAX 505.242.6412 WWW.UNI-RAC.COM