

SQFlex

Renewable-energy based water supply systems

The SQFlex system is a reliable water supply system especially suitable for remote locations not connected to the electricity supply grid. The SQFlex system is equipped with the SQF submersible pump.

The SQFlex system is powered by renewable energy sources.



TM02 2405 4201 - TM02 2408 4201 - TM02 2409 4201 - TM02 2410 4201

Contents

General data

| | | |
|-------------------|------|---|
| Performance range | Page | 3 |
| Application | Page | 4 |
| The SQFlex system | Page | 4 |
| Pumped liquids | Page | 5 |
| Type key | Page | 5 |
| Curve conditions | Page | 5 |
| Pump overview | Page | 6 |
| System overview | Page | 7 |

Features and benefits

| | | |
|-------------------------------------|------|----|
| Dry-running protection | Page | 8 |
| High efficiency | Page | 8 |
| Over- and undervoltage protection | Page | 8 |
| Overload protection | Page | 9 |
| Overtemperature protection | Page | 9 |
| Maximum Power Point Tracking (MPPT) | Page | 9 |
| Wide voltage range | Page | 9 |
| Reliability | Page | 10 |
| Installation | Page | 10 |
| Service | Page | 10 |

Application examples

| | | |
|---------------|------|----|
| SQFlex Solar | Page | 11 |
| SQFlex Wind | Page | 14 |
| SQFlex Combi | Page | 16 |
| SQFlex system | Page | 18 |

System components

| | | |
|------------------------|------|----|
| CU 200 | Page | 19 |
| Wiring diagram, CU 200 | Page | 20 |
| IO 100 | Page | 21 |
| Wiring diagram, IO 100 | Page | 21 |
| IO 101 | Page | 21 |
| Wiring diagram, IO 101 | Page | 21 |
| Generator | Page | 21 |
| Solar panels | Page | 22 |

System sizing

| | | |
|----------------------------|------|----|
| Selection of SQFlex system | Page | 24 |
| Example | Page | 24 |

Performance curves

| | |
|------|----|
| Page | 26 |
|------|----|

Technical data

| | | |
|---|------|----|
| Dimensions and weights | Page | 30 |
| Electrical data | Page | 30 |
| SQF pump | Page | 31 |
| IO 100 switch box | Page | 31 |
| IO 101 switch box | Page | 31 |
| CU 200 control unit | Page | 32 |
| GF 43 solar module | Page | 32 |
| Wiring diagram for pump | Page | 32 |
| Material specification - helical rotor pump | Page | 33 |
| Material specification - centrifugal pump | Page | 34 |
| Material specification - motor | Page | 35 |

Accessories

| | | |
|---|------|----|
| Submersible drop cable | Page | 36 |
| Cable termination kit, type KM | Page | 36 |
| Cable clips | Page | 36 |
| Straining wire | Page | 36 |
| Wire clamp | Page | 36 |
| Sizing tool | Page | 37 |
| Support structure | Page | 37 |
| Row closure kit | Page | 37 |
| Wire kit interpanel for GF 43 | Page | 37 |
| Wire kit array to control box for GF 43 | Page | 38 |
| Tower kit for H80 Whisper | Page | 38 |
| Tower installation kit | Page | 38 |
| Tower pipe selection | Page | 38 |
| Auger / anchor | Page | 39 |
| Grease | Page | 39 |
| Level switch | Page | 39 |

Product numbers

| | | |
|--|------|----|
| Complete unit with 2 m cable | Page | 40 |
| Pump without motor | Page | 40 |
| Motor without pump | Page | 40 |
| Submersible drop cables | Page | 40 |
| IO 100 | Page | 41 |
| IO 101 | Page | 41 |
| CU 200 | Page | 41 |
| Solar modules | Page | 41 |
| Wind turbine H80 Whisper incl. breaker box | Page | 41 |

Performance range

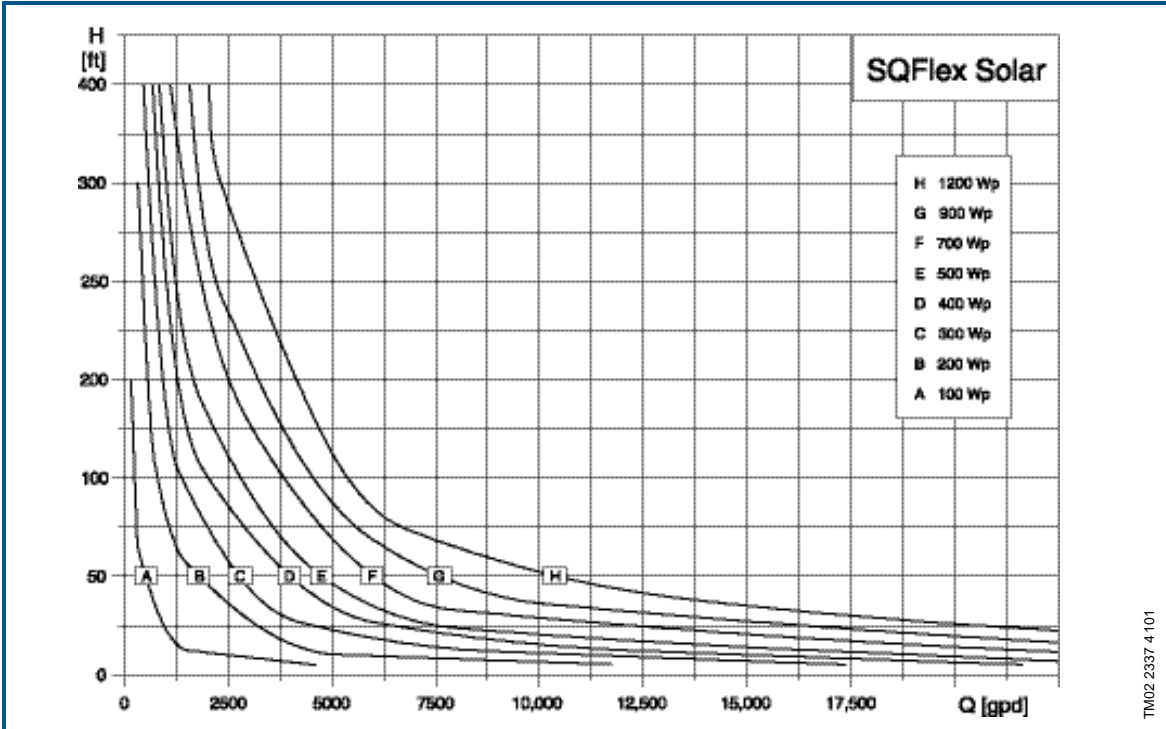

TM02 2337 4 101

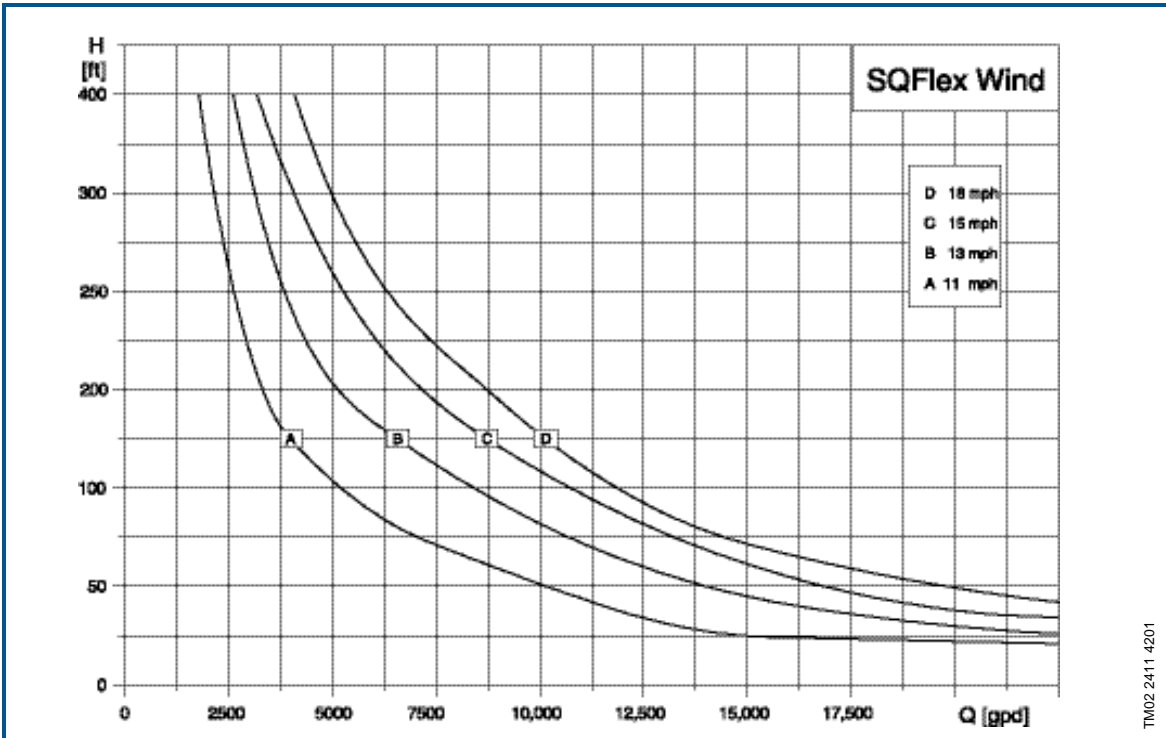

TM02 2411 4201

Note: Do not use the above curves for sizing of the pump.

Application

Being designed for continuous as well as intermittent operation the SQFlex system is especially suitable for water supply applications in remote locations, such as:

- villages, schools, hospitals, single-family houses, cabins, etc.
- farms
 - watering of cattle
 - irrigation of fields and greenhouses
- game parks and game farms
 - watering applications
- conservation areas
 - surface water pumping.

The SQFlex system

The SQFlex system is a reliable water supply system based on renewable energy sources, such as the sun and the wind energy.

Very flexible as to its energy supply and performance, the SQFlex system can be combined and adapted to any need according to the conditions on the installation site.

The system components are:

- SQF submersible pump
- CU 200 control unit
- IO 100 and IO 101 switch boxes
- energy supply:
 - solar panels
 - wind turbine
 - generator
 - batteries.

Pump

The SQF pump range comprises two pump technologies:

- Helical rotor pump (3") for high heads and small flows.
- Centrifugal pump (4") for low heads and large flows based on the Grundfos SP A pump.

All pump types are available in 304 stainless steel.

The performance curves below illustrate pump performance for the two pump technologies:

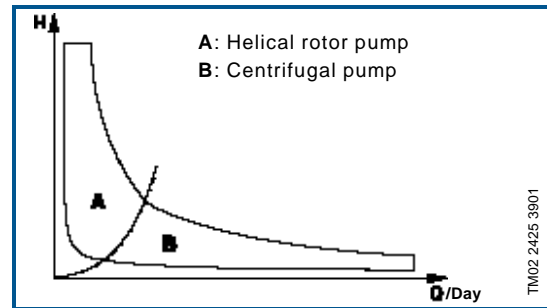

Motor

The SQFlex motor range comprises only one motor size, the MSF 3 with max. power input (P1) of 900 W. MSF 3 is a 3" motor. The speed range for the motor is 500-3000 rpm depending on the power input and the load. The motor has been developed especially for the SQFlex system.

The motor is available in 304 stainless steel.

The motor is designed according to the permanent-magnet principle with built-in electronic unit.

Voltage supply

The motor can be supplied with either AC or DC voltage.

- 30 - 300 VDC, PE
- 1 x 90 - 240 V -10%/+6%, 50/60 Hz, PE.

IO 100 switch box

The IO 100 is an on/off switch for closing and opening the system voltage supply.

The IO 100 switch box is used together with SQFlex systems supplied solely by solar panels.

IO 101 switch box

The IO 101 is an on/off switch for closing and opening the system voltage supply.

The IO 101 switch box is used with SQFlex systems supplied by solar panels and with a generator supply backup.

CU 200 control unit

The CU 200 control unit is a combined status and control unit for the SQFlex pump system. Furthermore, the CU 200 enables connection of a level switch placed in a water reservoir or similar tank.

Solar module

Grundfos' GF 43 solar module has been developed especially for the SQFlex system. The solar module is equipped with plugs and sockets enabling easy and simple installation.

Generator

In case the electricity supply from its primary source of energy is temporarily insufficient, the SQFlex system can be supplied by a generator.

Batteries

The SQFlex system can be supplied by batteries with a voltage supply of 30 - 300 VDC, minimum current 7A.

Pumped liquids

The SQF pumps are designed for pumping thin, clean, non-aggressive, non-explosive liquids, not containing solid or long-fibred particles larger than sand grains.

Sand content: max. 0.0067 oz/gal.

A higher sand content will reduce the pump life considerably due to wear.

pH: 5 - 9
Liquid temperature: 32°F to 104°F

The pump can run at free convection (~ 0 fps) at max. 104°F.

Type key

Type key for helical rotor pumps

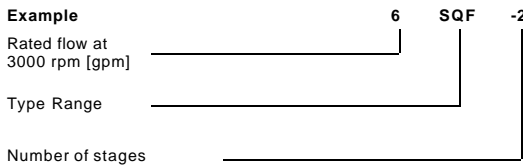

Type key for centrifugal pumps

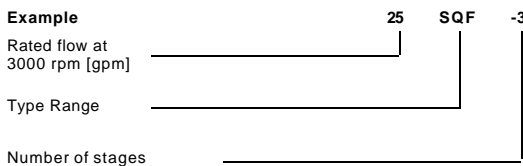

Curve conditions

The SQFlex Solar performance range shown on page 3 is based on:

- solar radiation on a tilted surface
- $H_T = 6$ kWh/m² per day
- 20° tilt angle
- ambient temperature: 85°F
- 20° northern latitude
- panel voltage: 120 VDC.

The SQFlex Wind performance range shown on page 3 is based on:

- average wind speed
- calculations according to Weibull's factor $k = 2$
- continuous operation over 24 hours.

The performance charts on pages 23 to 26 are based on the following guidelines:

- All curves show mean values.
- The curves must not be used as guarantee curves.
- Typical deviation: +/-15%.
- The measurements were made at a water temperature of 68°F.
- The curves apply to a kinematic viscosity of 1 mm²/s (1 cSt). If the pump is used for liquids with a viscosity higher than that of water, this will reduce the head and increase the power consumption.
- The performance curves are inclusive of inlet and valve losses at the actual speed.
- Supply to pump: 120 VDC.

Pump overview

The SQF pump is available as a complete unit as well as a flexible concept.

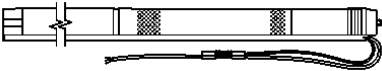
| Element | Drawing | Description |
|-------------------|---|---|
| SQF pump complete |  | TM02 2217 3901 SQF pump complete with ... <ul style="list-style-type: none"> • motor • 6 ft. cable with water level electrode, end cover, socket and • cable guard. |





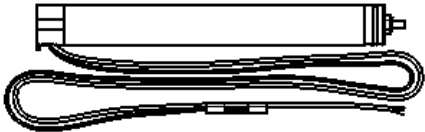



















Flexible concept

Flexible concept means that the pump and motor can be ordered separately.

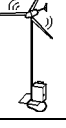
| Element | Drawing | Description |
|--------------------|--|---|
| Pump without motor |  | TM02 2218 3901 - TM02 2221 3901 7 pump types (helical rotor and centrifugal pumps) delivered with cable guard adjusted to the pump. Note: The cable guard for the centrifugal pump types is divided in two pieces, one for the pump and one for the motor. |
| Motor without pump |  | TM01 2219 3901 MSF 3 motor with 6 ft. cable with water level electrode, end cover and socket. |

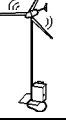
System overview

The SQFlex system can be used in a number of combinations as shown in the table below.

| System ... | ... consists of the following components | | | | | | | |
|---|---|---|---|--|---|---|---|--|
| | Pump | Solar panel * | Wind turbine | Generator | Switch box | Switch box | Control unit | Level switch |
| SQFlex Solar See page 11. |  |  | | |  | | | |
| SQFlex Solar - with CU 200 control unit and level switch See page 12. |  |  | | | | |  |  (**) |
| SQFlex Solar - with generator as power supply back-up See page 13. |  |  | |  | |  | | |
| SQFlex Wind See page 14. |  | |  | | | | | |
| SQFlex Wind - with CU 200 control unit and level switch See page 15. |  | |  | | | |  |  (**) |
| SQFlex Combo - combination of solar and wind energy See page 16. |  |  |  | | | | | |
| SQFlex Combo - with CU 200 and level switch See page 17. |  |  |  | | | |  |  (**) |
| SQFlex system - with generator as power supply See page 18. |  | | |  | | | | |

* For the number of solar modules required, please consult the Sizing tool.

** Can be excluded from the installation.

Dry-running protection

The SQF pump is protected against dry running in order to prevent damage to the pump. The dry-running protection is activated by a water level electrode placed on the motor cable 12-24 inches above the pump depending on the pump type.

The water level electrode measures the contact resistance to the motor sleeve through the water. When the water level falls below the water level electrode the pump will be cut out. The pump will automatically cut in again 5 min. after the water level is above the water level electrode.

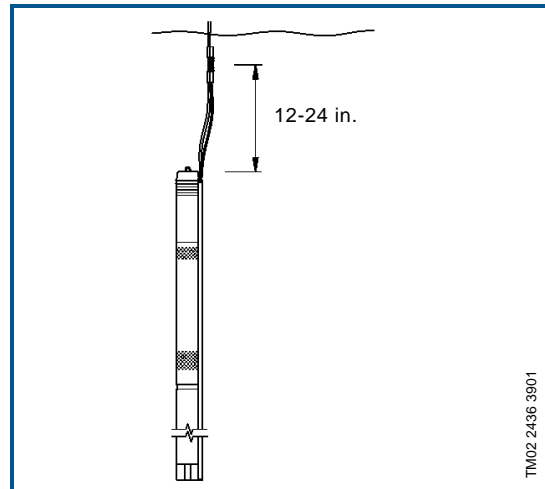

High efficiency

The MSF 3 motor is a permanent-magnet motor (PM motor) featuring a higher efficiency within the power range compared to a conventional asynchronous motor.

In addition to this the segmented motor stator contributes considerably to the high efficiency.

The MSF 3 motor is furthermore characterised by a high locked-rotor torque even at low power supply.

Over- and undervoltage protection

Overvoltage and undervoltage may occur in case of unstable voltage supply.

The pump will be cut out if voltage falls outside the permissible voltage range. The motor is automatically cut in again when the voltage is again within the permissible voltage range. Therefore no extra protection relay is needed.

Note: The MSF 3 motor is protected against transients from the the voltage supply according to IEC 60664-1 "overvoltage category III" (4 kV). In areas with high lightning intensity, external lightning protection is recommended.

Overload protection

If the upper power input limit is exceeded or if the pump is blocked, the motor will automatically compensate for this by reducing the speed. If the speed falls below 500 rpm, the motor will be cut out automatically.

The motor will remain cut out for 5 minutes after which period the pump will automatically attempt a restart.

The overload protection prevents burnout of the motor. Consequently, no extra motor protection is required.

Overtemperature protection

A permanent-magnet motor gives off very little heat to its surroundings. In combination with an efficient internal circulation system leading the heat away from the rotor, stator and bearings, this fact ensures optimum operating conditions for the motor.

As an extra protection, the electronic unit has a built-in temperature sensor. When the temperature rises above 185°F, the motor is automatically cut out; when the temperature has dropped to 165°F, the motor is automatically cut in again.

Maximum Power Point Tracking (MPPT)

The built-in electronic unit gives the SQFlex system a number of advantages compared to conventional products. One of these advantages is the built-in micro-processor with MPPT (MPPT = **M**aximum **P**ower **P**oint **T**racking).

Thanks to the MPPT-function, the pump duty point is continuously optimised according to the input power available. MPPT is only available for pumps connected to DC supply.

Wide voltage range

The wide voltage range enables the motor to operate at any voltage from 30-300 VDC or 90-240 VAC. This makes installation and sizing especially easy.

Reliability

The MSF 3 has been developed with a view to high reliability which is achieved through the following features:

- carbon/ceramic bearings
- excellent starting capabilities
- various protection facilities.

Installation

The following features ensure simple installation of the SQF pump:

- low weight ensuring user-friendly handling
- installation in 3", 4" or larger boreholes
- only an on/off switch is needed, which means that no extra motor starter / starter box is necessary, and
- SQF is available with cable with cover and socket.

Note: Horizontal installation requires the water level electrode to be placed min. 12-24 inches above the pump to ensure the dry-running protection.

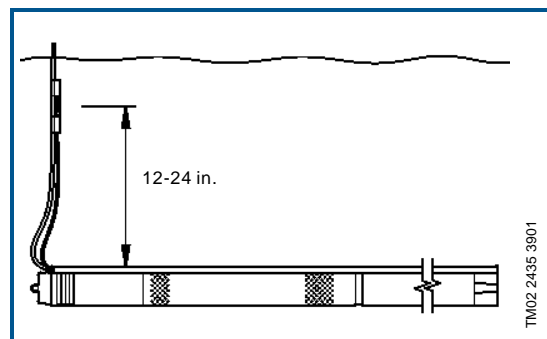
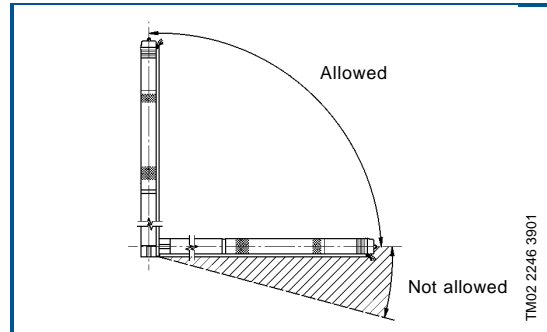

Service

The modular pump and motor design facilitates installation and service. The cable and the end cover with socket are fitted to the pump with nuts which enable replacement.

SQFlex Solar

The SQFlex Solar system is the simplest of the range of SQFlex systems.

Benefits

- Easy to install
- Maintenance confined to periodic cleaning of the solar panels
- Few and simple components.

The protective circuit incorporated in the motor electronic unit cuts out the pump in case of dry running or similar situations.

By using the IO 100 switch box, the voltage supply to the pump can be closed manually, e.g. when ...

- there is no need for water supply
- the system requires service.

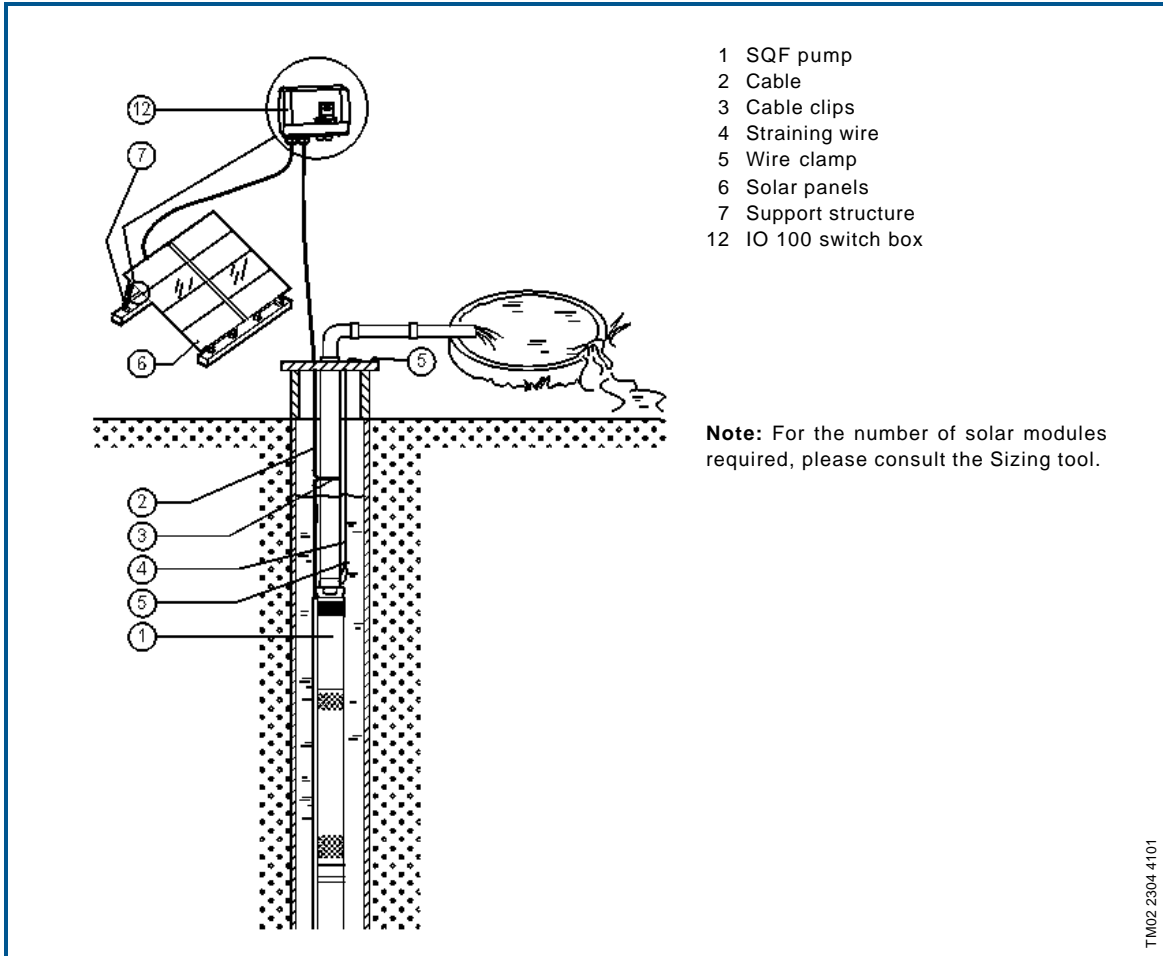

SQFlex Solar

- with CU 200 control unit and level switch

The SQFlex Solar system allows energy from the sun to be stored as water in a reservoir.

SQFlex Solar water supply systems with a water reservoir are used where ...

- there is a need for night-time water supply
- for short periods, the solar energy is insufficient to run the pump
- there is a need for a back-up water source.

Benefits

Combined with the CU 200, the level switch acts as a pump cut-out function when the water reservoir is full.

CU 200 offers indication of ...

- full water reservoir (level switch activated)
- pump operation
- input power.

CU 200 indicates operational stoppage in case of ...

- dry running
- service (see page 19)
- insufficient energy supply.

In addition, the system features ...

- easy installation
- maintenance confined to periodic cleaning of the solar panels.

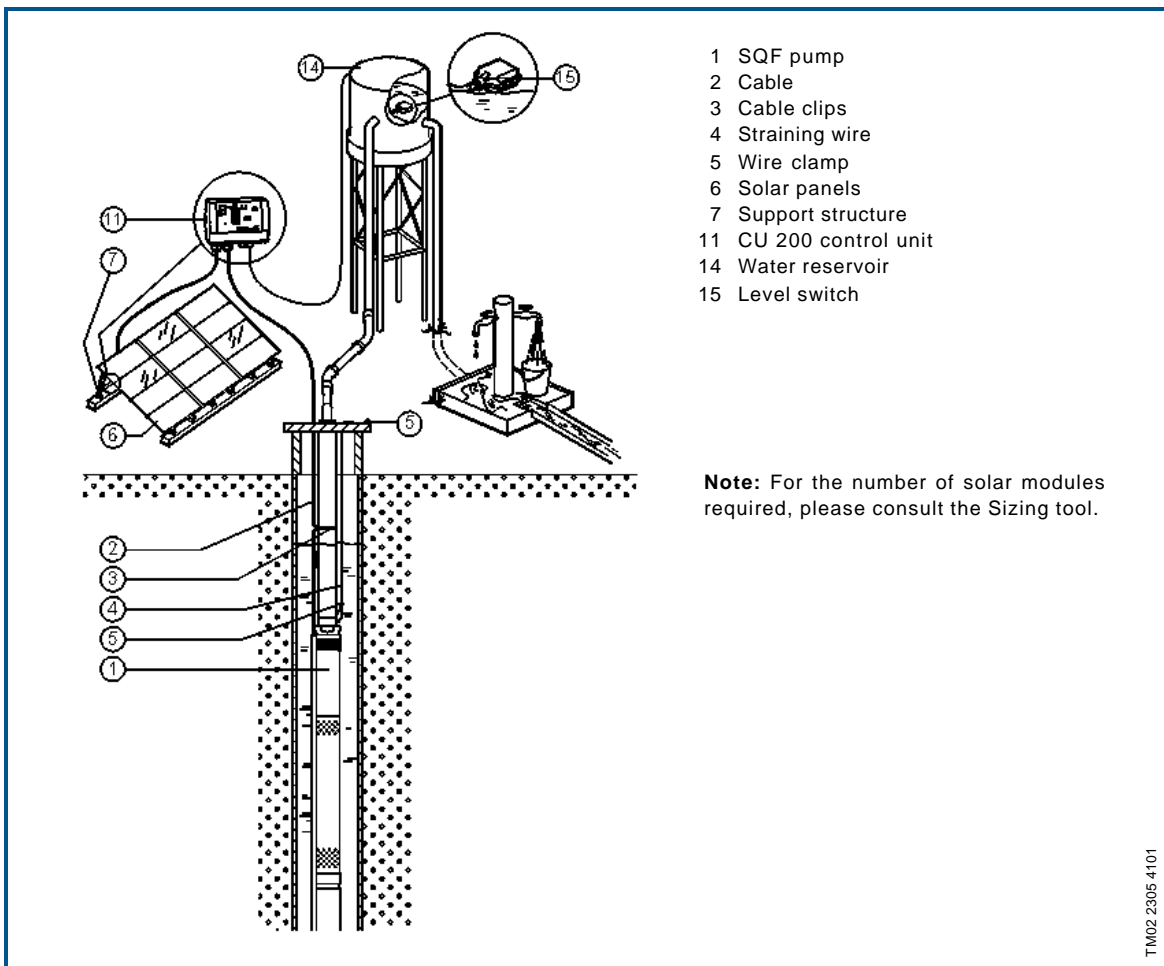

- 1 SQF pump
- 2 Cable
- 3 Cable clips
- 4 Straining wire
- 5 Wire clamp
- 6 Solar panels
- 7 Support structure
- 11 CU 200 control unit
- 14 Water reservoir
- 15 Level switch

Note: For the number of solar modules required, please consult the Sizing tool.

TM02 2305 4101

SQFlex Solar

- with generator as power supply back-up

During periods of limited solar energy, the SQFlex Solar water supply system provides a safe supply of water. The system is connected to an external generator as back-up via the IO 101 switch box.

The system enables operation ...

- via generator when ...
 - the energy supply from the solar panels is insufficient
- via solar energy when ...
 - the generator is stopped manually
 - the generator runs out of fuel.

Benefits

- Offers water supply at night or when the solar energy is insufficient
- Easy to install
- Maintenance confined to periodic cleaning of the solar panels
- Few and simple components
- Flexible in terms of energy supply.

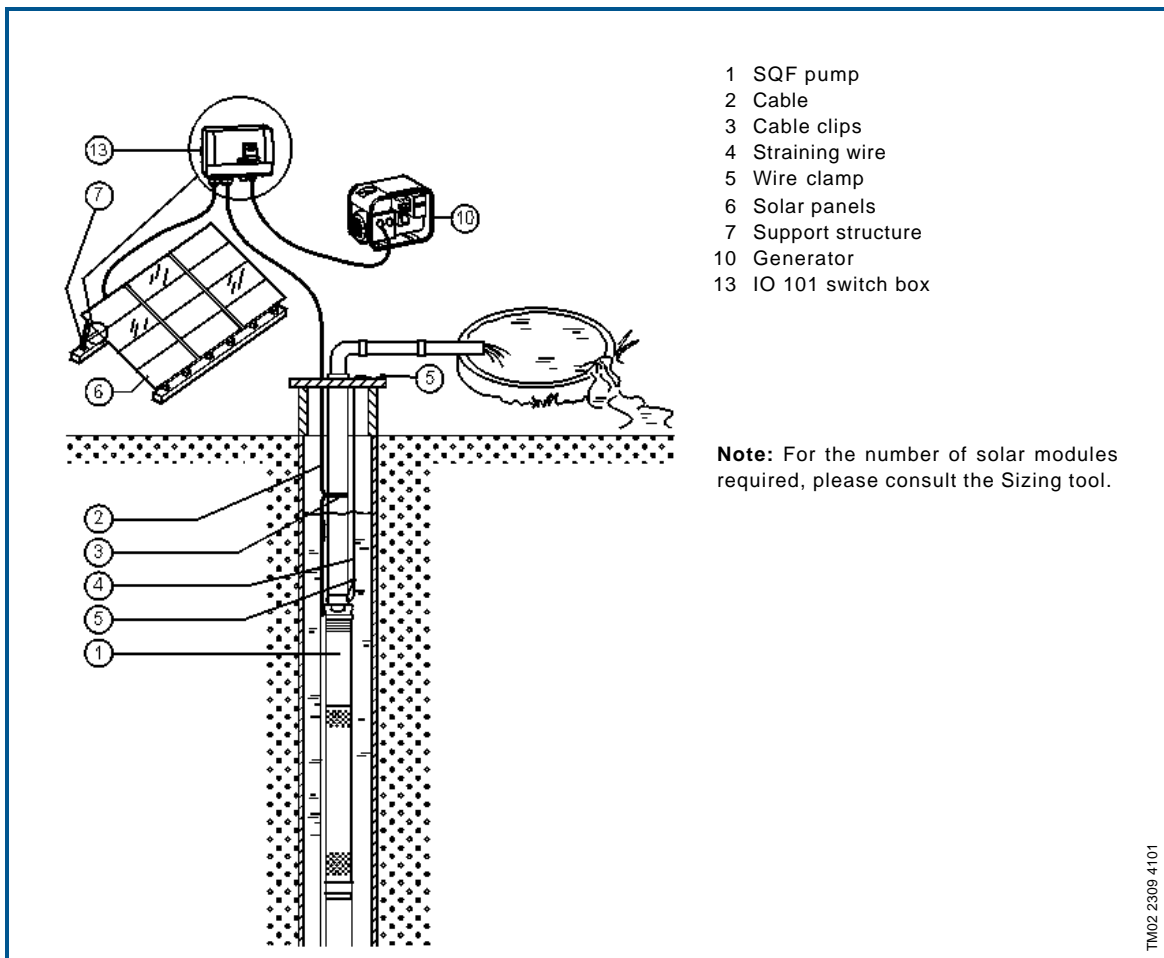

SQFlex Wind

The SQFlex Wind system is based on wind energy as the only energy source for pump operation.

The system is suitable for installation in areas where the wind is almost constant seen over a period of time.

As the turbine noise level increases with the wind speed, siting of the wind turbine near a residence is not recommended.

The breaker box makes it possible to brake the wind turbine when ...

- there is no need for water supply
- the system requires service.

Benefits

- Easy to install
- A minimum of maintenance required
- Few and simple components.

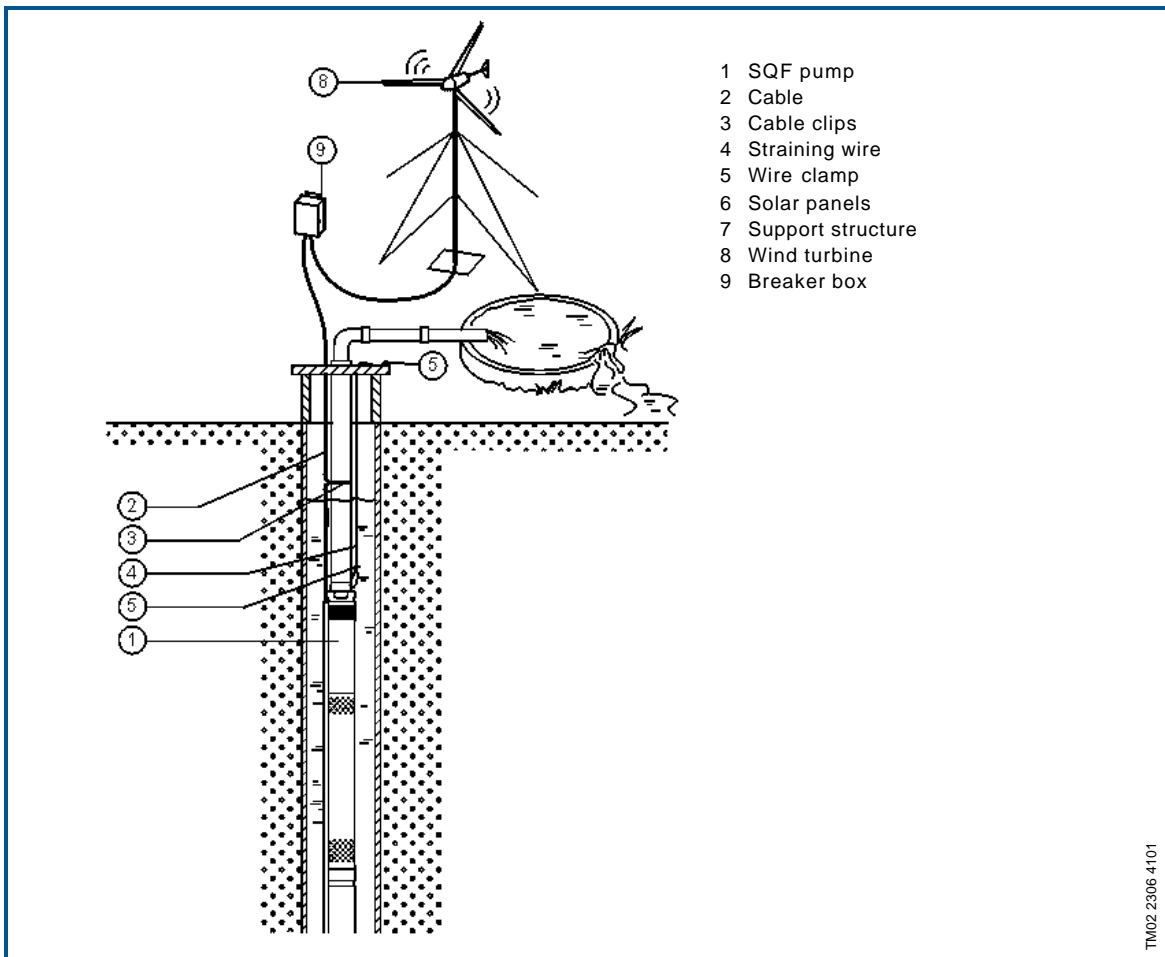

SQFlex Wind

- with CU 200 control unit and level switch

The SQFlex Wind system allows energy from the wind to be stored as water in a reservoir.

SQFlex Wind water supply systems with a water reservoir are used where ...

- for short periods, the wind energy is insufficient to run the pump
- there is a need for a back-up water source.

As the turbine noise level increases with the wind speed, siting of the wind turbine near a residence is not recommended.

Benefits

Combined with the CU 200, the level switch acts as a pump cut out function when the water reservoir is full.

CU 200 offers indication of ...

- full water reservoir (level switch activated)
- pump operation
- input power.

CU 200 indicates operational stoppage in case of ...

- dry running
- service (see page 19)
- insufficient energy supply.

The breaker box makes it possible to interrupt the supply voltage in the system and to slow down or stop the wind turbine when ...

- there is no need for water supply
- the system requires service.

In addition, the system features ...

- easy installation
- a minimum of maintenance.

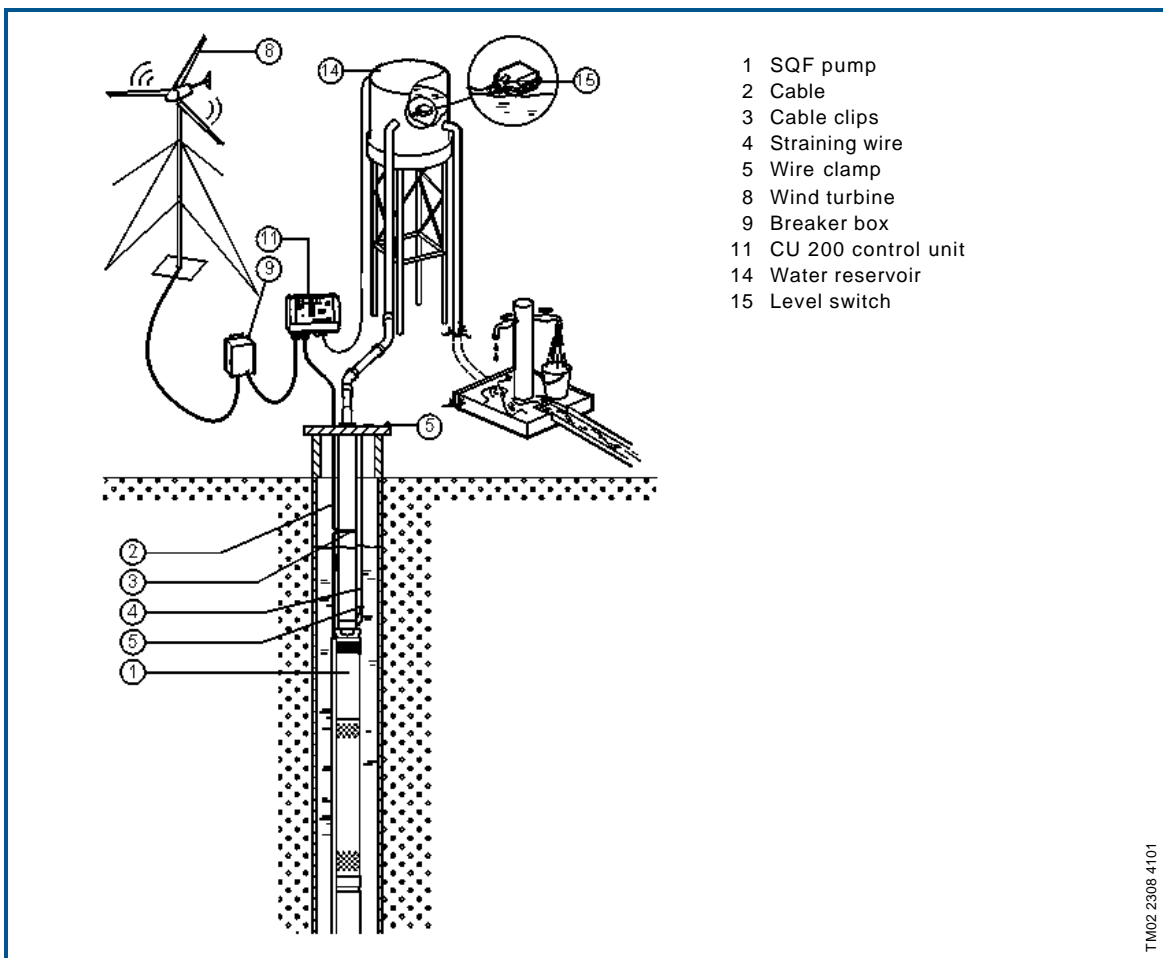

SQFlex Combo

- combination of solar and wind energy

The SQFlex Combi water supply system is ideal in areas where the solar or wind energy is sufficient to run the pump.

The energy supply to the pump is a combination of solar and wind energy.

As the turbine noise level increases with the wind speed, siting of the wind turbine near a residence is not recommended.

Benefits

- Offers water supply at night or when the solar energy is insufficient
- Easy to install
- Maintenance confined to periodic cleaning of the solar panels
- Few and simple components.

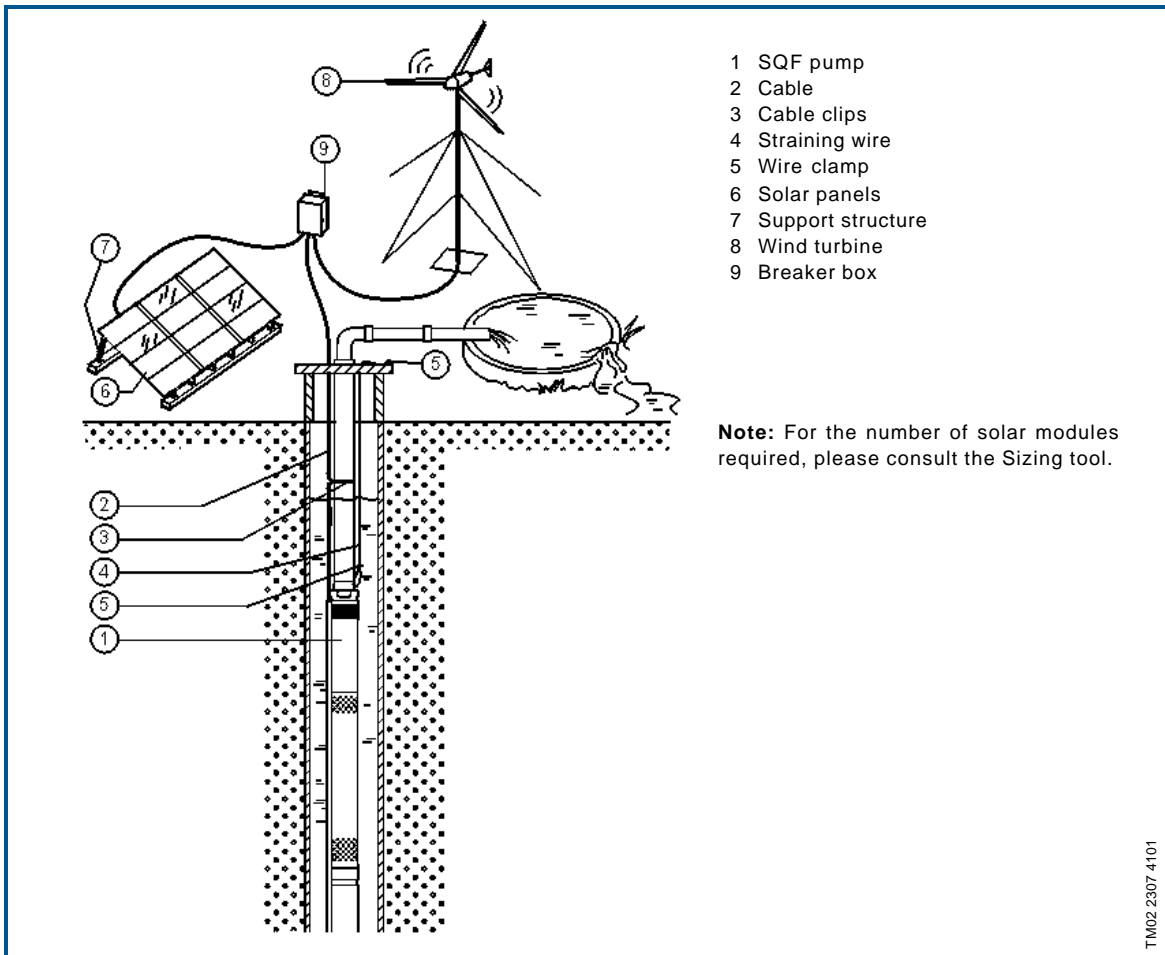

SQFlex Combo

- with CU 200 and level switch

The SQFlex Combi system allows solar and wind energy to be stored as water in a reservoir.

SQFlex Combi water supply systems with a water reservoir are used where ...

- for short periods, the solar or wind energy is insufficient to run the pump
- there is a need for a back-up water source.

As the turbine noise level increases with the wind speed, siting of the wind turbine near a residence is not recommended.

Benefits

Combined with the CU 200, the level switch acts as a pump cut-out function when the water reservoir is full.

CU 200 offers indication of ...

- full water reservoir (level switch activated)
- pump operation
- input power.

CU 200 indicates operational stoppage in case of ...

- dry running
- service (see page 19)
- insufficient energy supply.

The breaker box makes it possible to interrupt the supply voltage in the system and to slow down or stop the wind turbine when ...

- there is no need for water supply
- the system requires service.

In addition, the system features ...

- easy installation
- a minimum of maintenance.

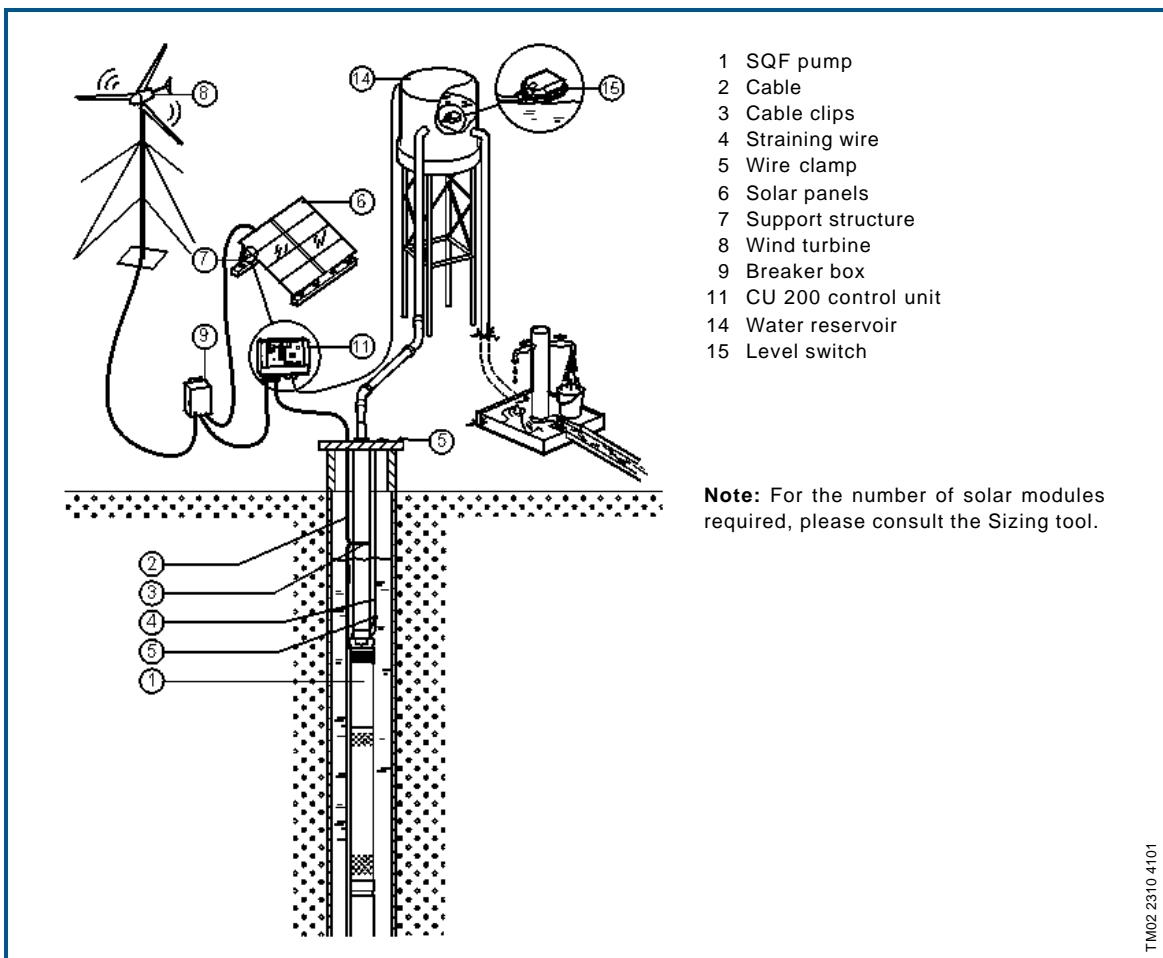

SQFlex system

- with generator as power supply

The SQFlex water supply system is connected to a generator, which can be diesel or petrol driven.

Benefits

- Offers water supply 24 hours a day independent of the weather.
- Easy installation.
- A minimum of maintenance required.
- Few and simple components.

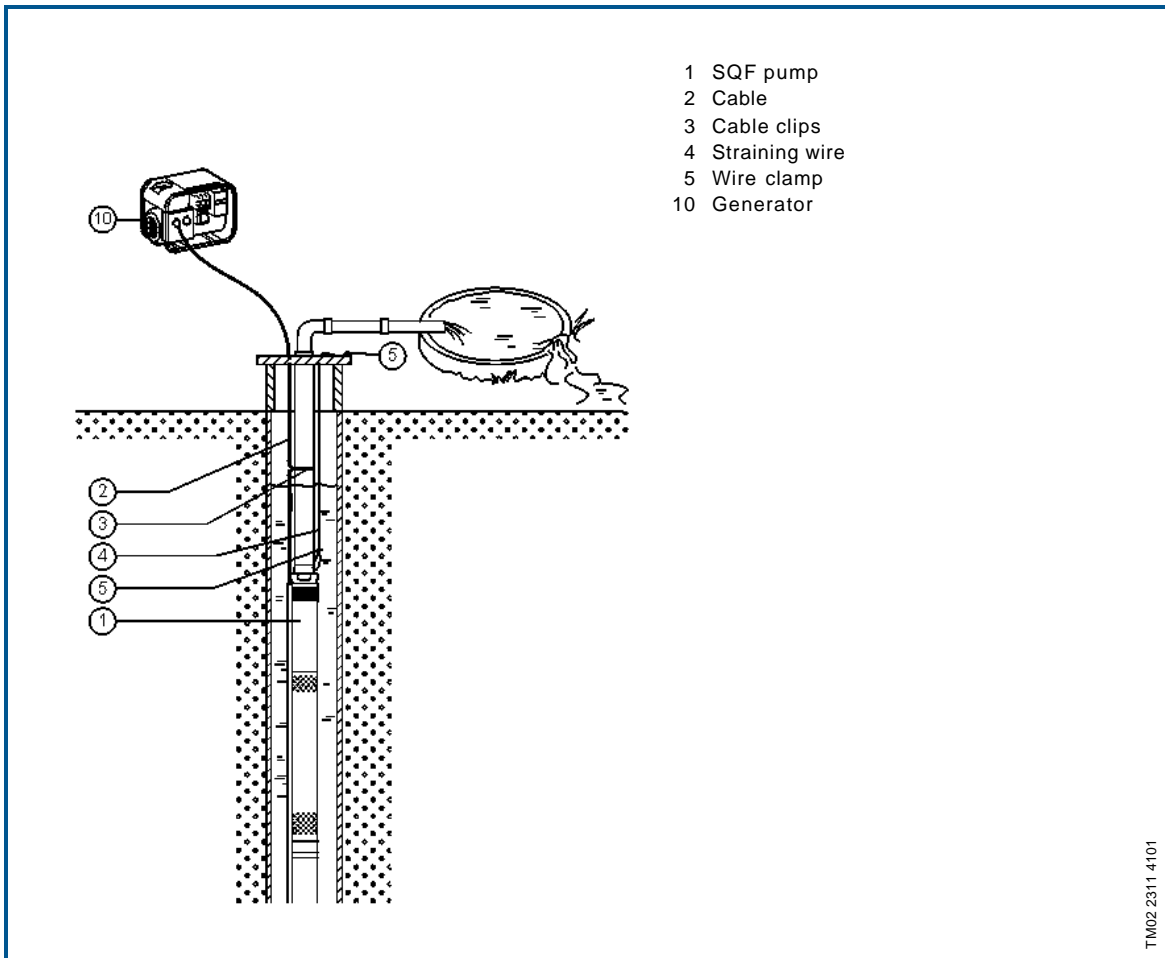

CU 200

The CU 200 control unit is a combined status, control and communication unit especially developed for the SQFlex system. Furthermore, the CU 200 enables connection of a level switch.

The CU 200 incorporates cable entries for ...

- power supply connection (pos. 6),
- pump connection (pos. 7),
- earth connection (pos. 8),
- level switch connection (pos. 9).

(The position numbers shown in brackets refer to the drawing to the right).

Communication between the CU 200 and the pump takes place via the pump power supply cable. This is called mains borne signalling (or Power Line Communication), and this principle means that no extra cables between the CU 200 and the pump are required.

It is possible to start, stop and reset the pump by means of the on/off button (pos. 1).

The CU 200 control unit offers:

- System monitoring
- Alarm indication.

The following indications allow the operation of the pump to be monitored:

- Water reservoir is full (level switch) (pos. 2)
- Pump is running (pos. 3)
- Input power (pos. 11).

The CU 200 offers the following alarm indications:

- Dry running (pos. 10)
- Service needed (pos. 5) in case of:
 - no contact to pump
 - overvoltage
 - overtemperature
 - overload.

In addition, the CU 200 shows the symbols of the energy supply options (pos. 4).

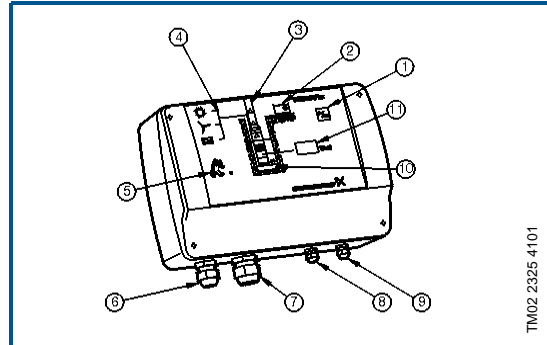

TM02 2325 4101

Dimensions, CU 200

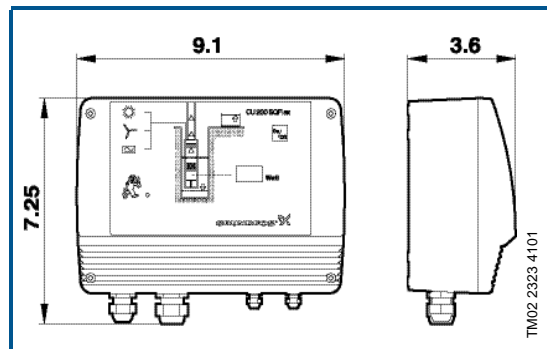

TM02 2323 4101

Dimensions stated in inches.

Wiring diagram, CU 200

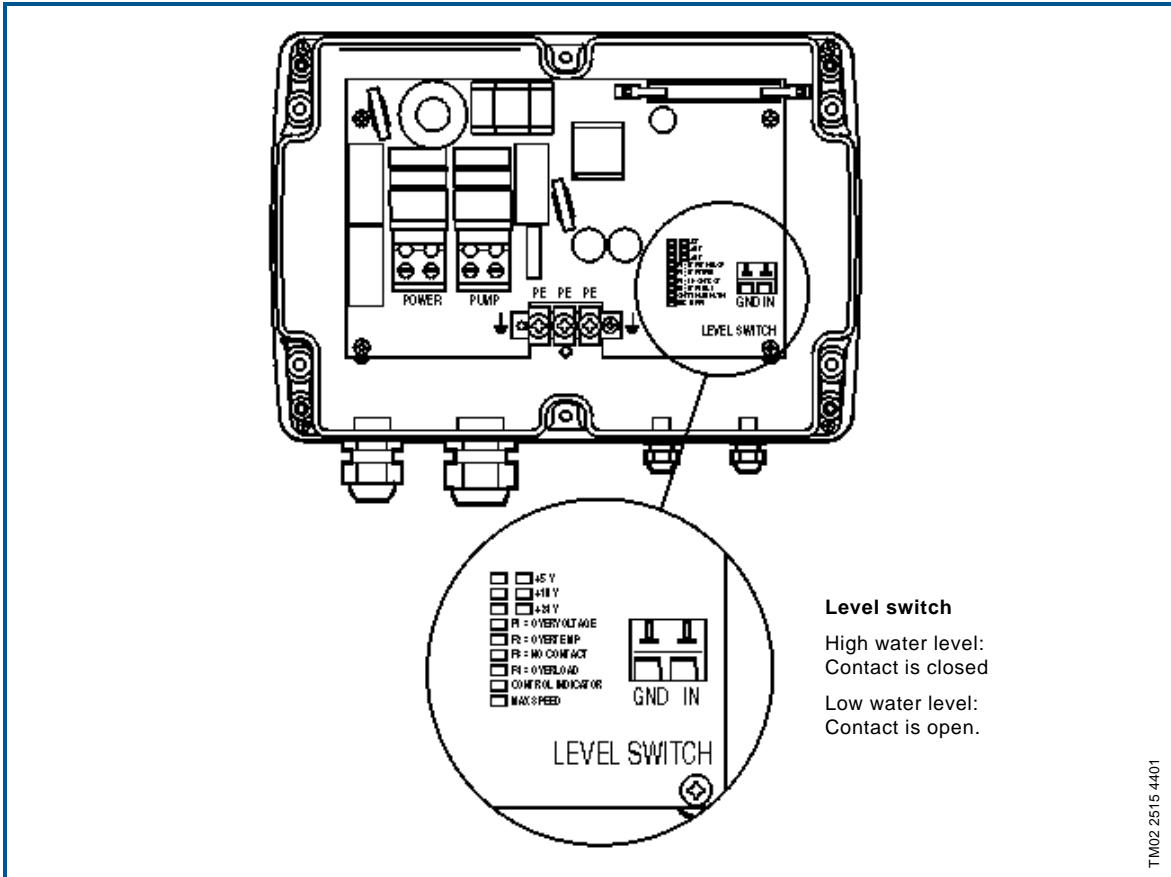

IO 100

The IO 100 switch box is designed specifically for solar powered SQFlex systems.

The IO 100 enables manual starting and stopping of the pump in an SQFlex Solar system and functions as a connection box joining all necessary cables.

The dimensions and wiring diagram of IO 100 are shown below.

Dimensions, IO 100

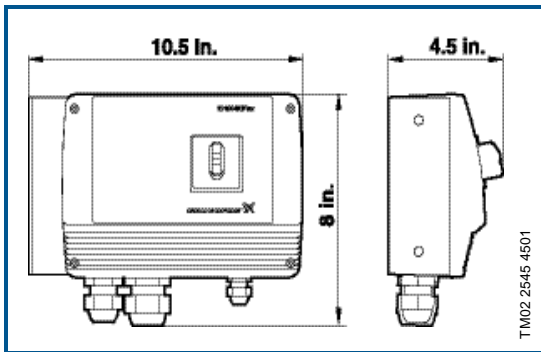

Dimensions stated in inches.

Wiring diagram, IO 100

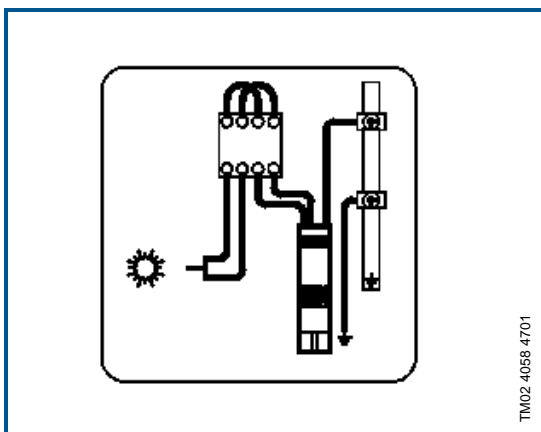

IO 101

The IO 101 switch box is designed specifically for solar powered SQFlex systems.

The IO 101 enables the connection of a generator supply back-up in case of insufficient solar radiation. The switching between solar power and generator must be made manually.

In case the generator is stopped manually or runs out of fuel, the IO 101 will automatically switch to the solar energy supply.

The IO 101 functions as a connection box joining all necessary cables.

The dimensions and wiring diagram of IO 101 are shown below.

Dimensions, IO 101

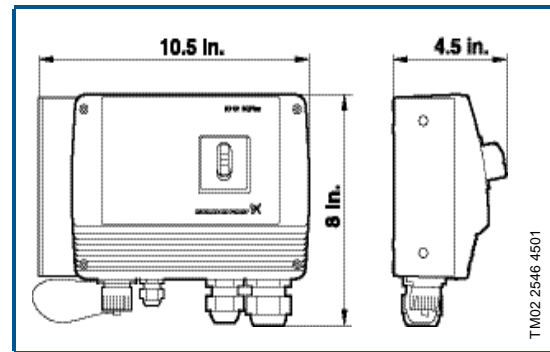

Dimensions stated in inches.

Wiring diagram, IO 101

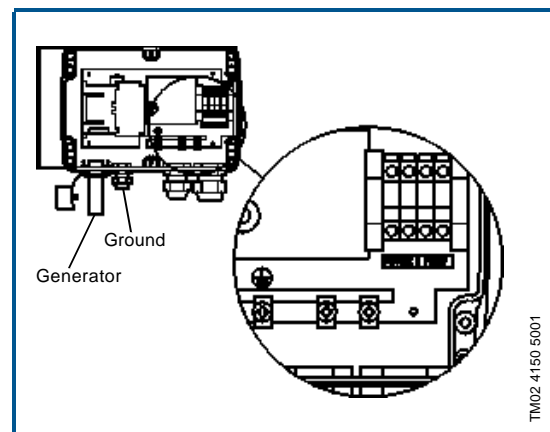

Generator

The generator must be running steadily before the pump is cut in.

Solar panels

The GF 43 solar module is of the amorphous silicium, thin-film type.

The solar module is equipped with plugs and sockets for easy connection of several modules in parallel. The solar panels are mounted on a support structure, tilted at an angle ensuring optimum utilization of the solar energy. The number of solar modules is determined by means of the Sizing tool, see page24.

The illustration below shows a solar panel with plugs and sockets.

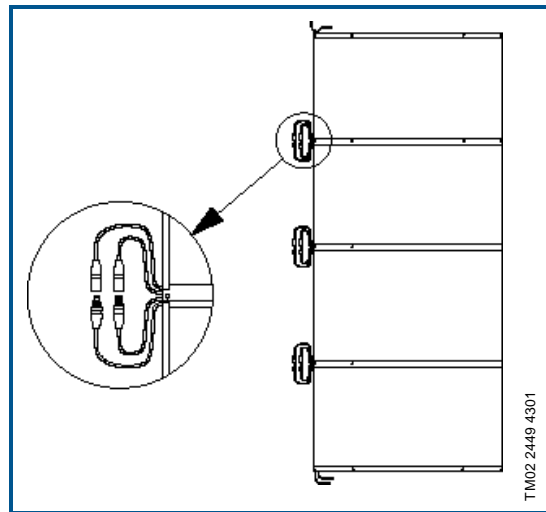

Dimensions, GF 43 module

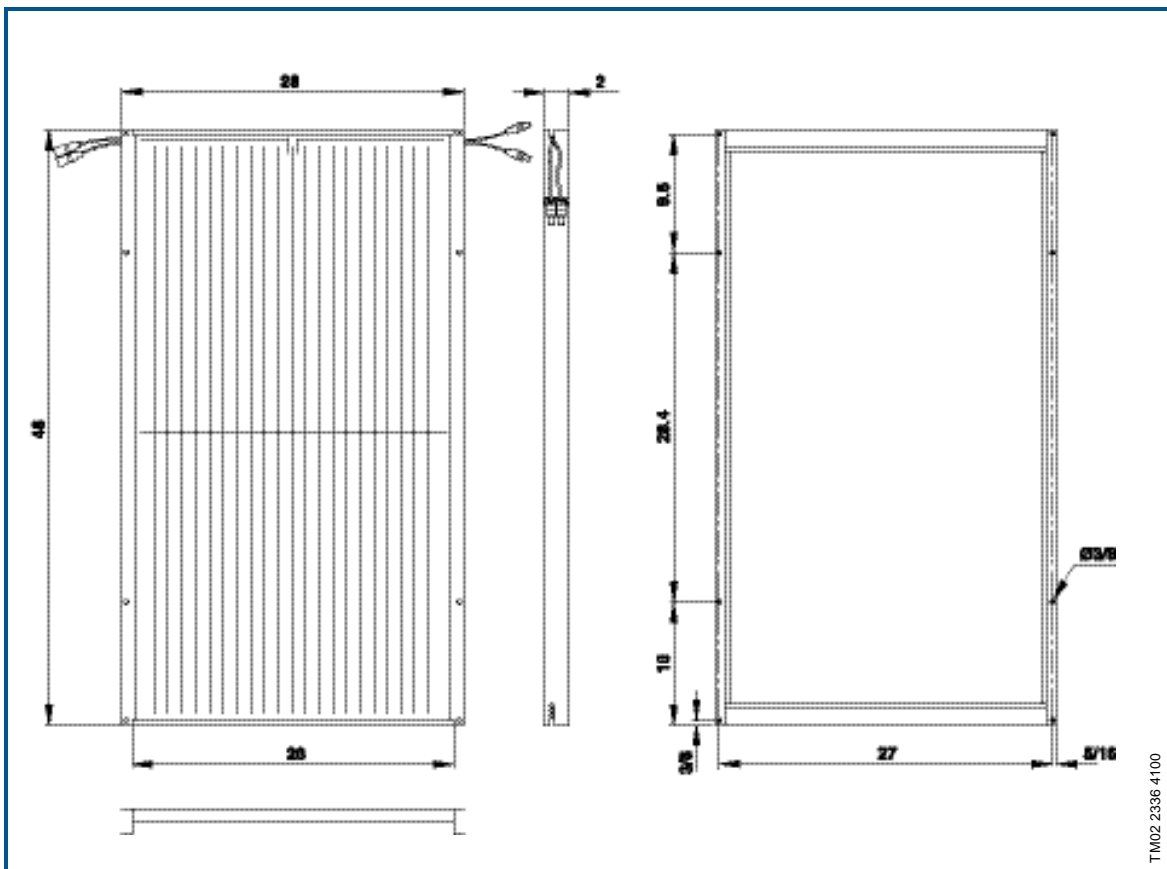

Dimensions stated in mm.

Selection of SQFlex system

Grundfos has developed a PC-based sizing tool enabling the selection of SQFlex systems. The sizing tool is also available in a paper version.

The PC-based sizing tool is integrated in WinCAPS and covers both solar and wind powered systems. The paper version covers only solar powered systems.

The following three parameters must be known for the selection of the optimum SQFlex system:

- installation location
- max. head required and
- quantity of water required.

With a view to the sizing of a correct solar powered SQFlex system the world has been divided into six regions:

- North America
- South America
- Australia/New Zealand
- Asia/Pacific
- Southern Africa
- Europe/Middle East/Northern Africa.

Each region is divided into a number of zones according to the solar radiation in kWh/m² per day.

The following example shows the selection of a solar powered SQFlex system using the paper version of the sizing tool.

For the sizing of a wind powered SQFlex system, please refer to the WinCAPS version.

Example

Conditions:

- installation location: Johannesburg, South Africa
- required head: 70 m
- quantity of water required: 4.7 m³/day

Proceed as follows:

1. Find Johannesburg on the map.
The map shows that Johannesburg is located in solar radiation zone K, and the recommended tilt angle of the solar panel is 30°.
2. Go to the selection table and find zone K and tilt angle 30°.
3. Find the required head (A) and the required flow (B) and read the recommended SQF pump type (C), number of solar modules (D) and the output power of the solar modules (E).

SQFlex system configuration:

Pump: SQF 1.2-2.

Number of solar modules: 8.

Power: 43 Wp x 8 = 344 Wp.

Finally, determine the material variant on the basis of the chemical composition of the pumped liquid.

Southern Africa (January)

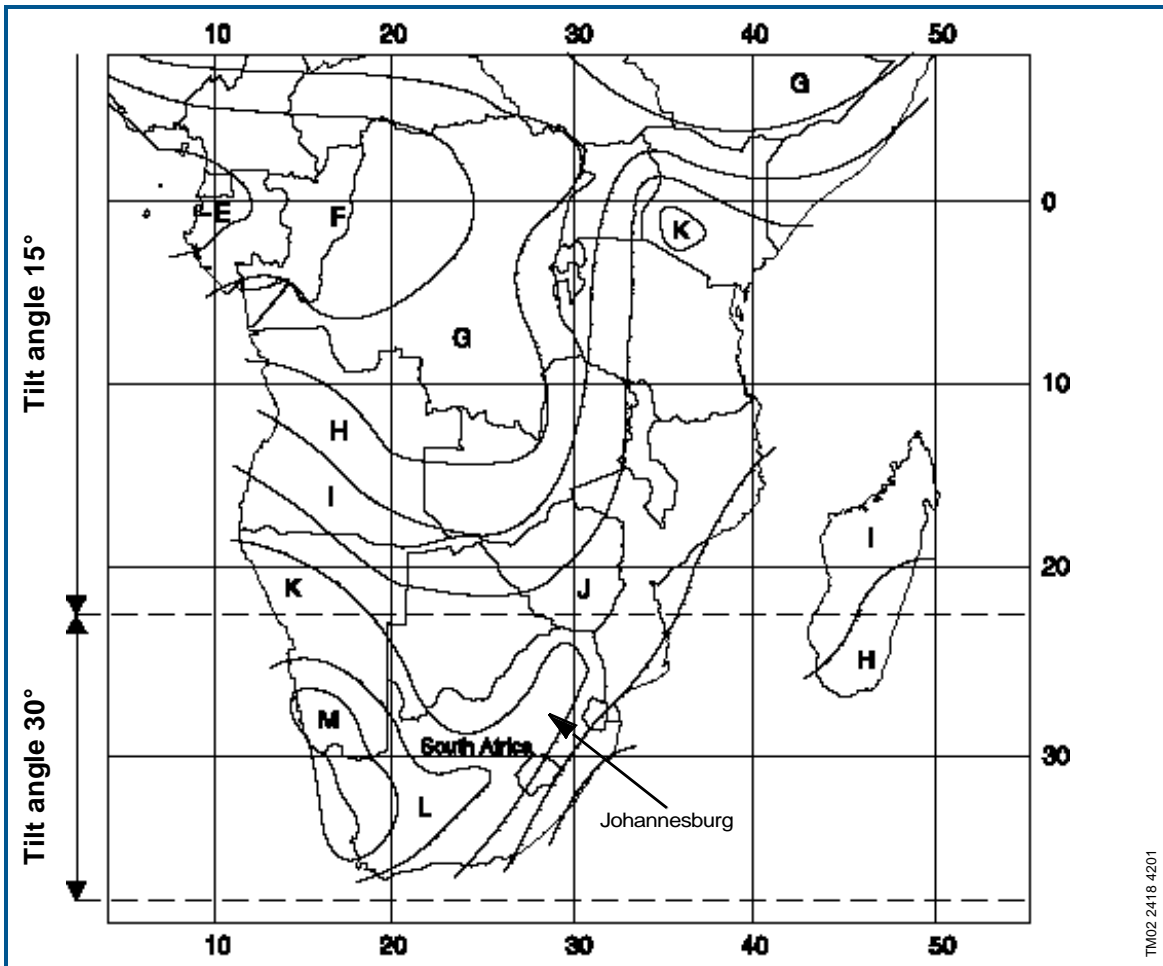

Sizing table

| Zone | Solar radiation | Required head [m] | | | | | | | | | | | | No. of solar modules GF 43 | Power [Wp] | |
|-------------------------|--------------------------------|-------------------------------------|-----------|-----------|------|-----------|---------------|-----------|---------|-----------|-----|-----------|-----|----------------------------|------------|---------|
| | | 5 | 10 | 20 | 30 | 40 | 50 | 60 | 70 (A) | 80 | 90 | 100 | 110 | | | 120 |
| Zone K - tilt angle 30° | 7.3 kWh/m ² per day | Required flow [m ³ /day] | | | | | | | | | | | | 4 | 172 | |
| | | 22.3 | 12.1 | 8.5 | 4.5 | 3.1 | 2.7 | 2.4 | 2.1 | 1.9 | 1.6 | 1.4 | 1.1 | | | 0.8 |
| | | SQF 5A-3 | SQF 2.5-2 | | | SQF 1.2-2 | SQF 0.6-2 | | | | | | | | 8 (D) | 344 (E) |
| | | 52.8 | 25.7 | 17.5 | 12.1 | 8.5 | 6.4 | 5.5 | 4.7 (B) | 4.1 | 3.8 | 3.5 | 3.2 | 2.8 | | |
| | | SQF 14A-3 | SQF 5A-3 | SQF 2.5-2 | | | SQF 1.2-2 (C) | | | SQF 0.6-2 | | | | | 12 | 516 |
| | | 78.8 | 40.2 | 21.5 | 17.9 | 14.1 | 11.1 | 8.6 | 7.4 | 6.7 | 5.8 | 5.1 | 4.3 | 4.0 | | |
| | | SQF 14A-3 | SQF 5A-3 | SQF 2.5-2 | | | | SQF 1.2-2 | | | | SQF 0.6-2 | 16 | 688 | | |
| | | 98.6 | 59.1 | 29.1 | 20.4 | 17.6 | 15.2 | 12.7 | 9.7 | 8.2 | 7.5 | 6.9 | | | 6.3 | 5.7 |
| | | SQF 14A-3 | SQF 5A-6 | SQF 2.5-2 | | | | SQF 1.2-2 | | | | 20 | 860 | | | |
| | | 115 | 75.0 | 37.6 | 22.2 | 19.5 | 17.4 | 15.4 | 12.9 | 10.6 | 8.4 | | | 7.9 | 7.3 | 6.8 |
| SQF 14A-3 | SQF 5A-6 | SQF 2.5-2 | | | | SQF 1.2-2 | | | | 20 | 860 | | | | | |
| 115 | 75.0 | 37.6 | 22.2 | 19.5 | 17.4 | 15.4 | 12.9 | 10.6 | 8.4 | | | 7.9 | 7.3 | 6.8 | | |

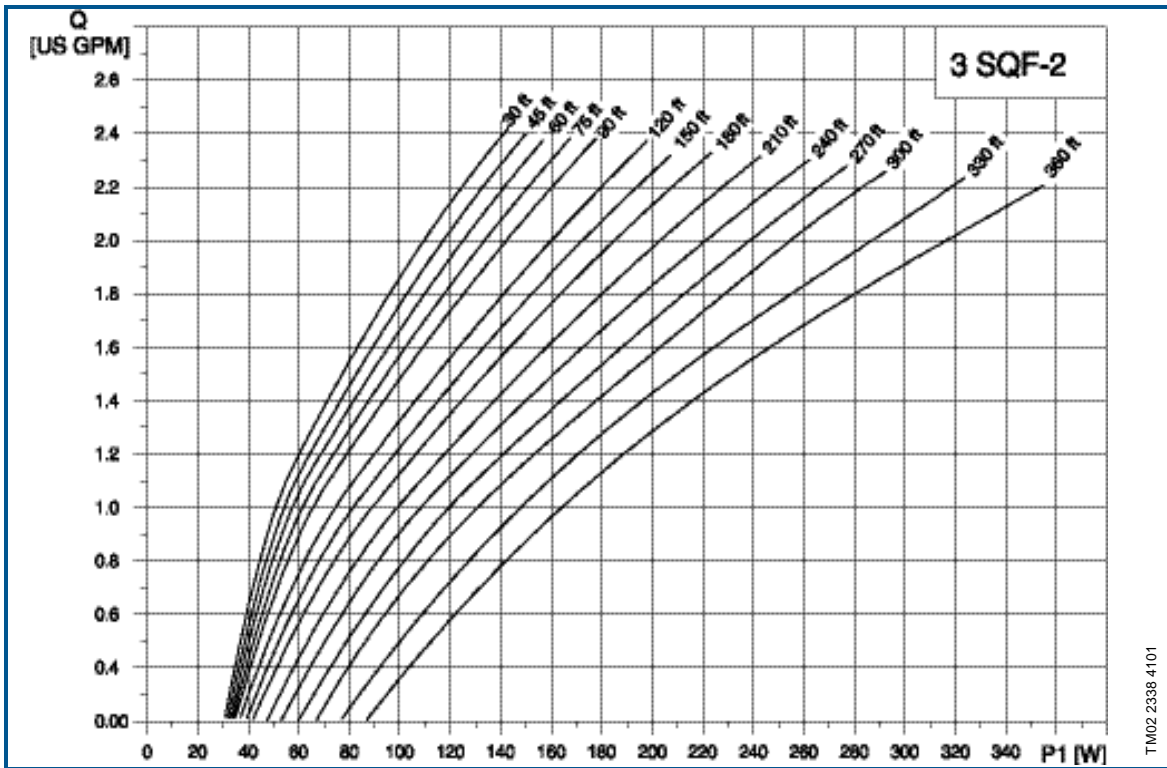

TM02 2338 4101

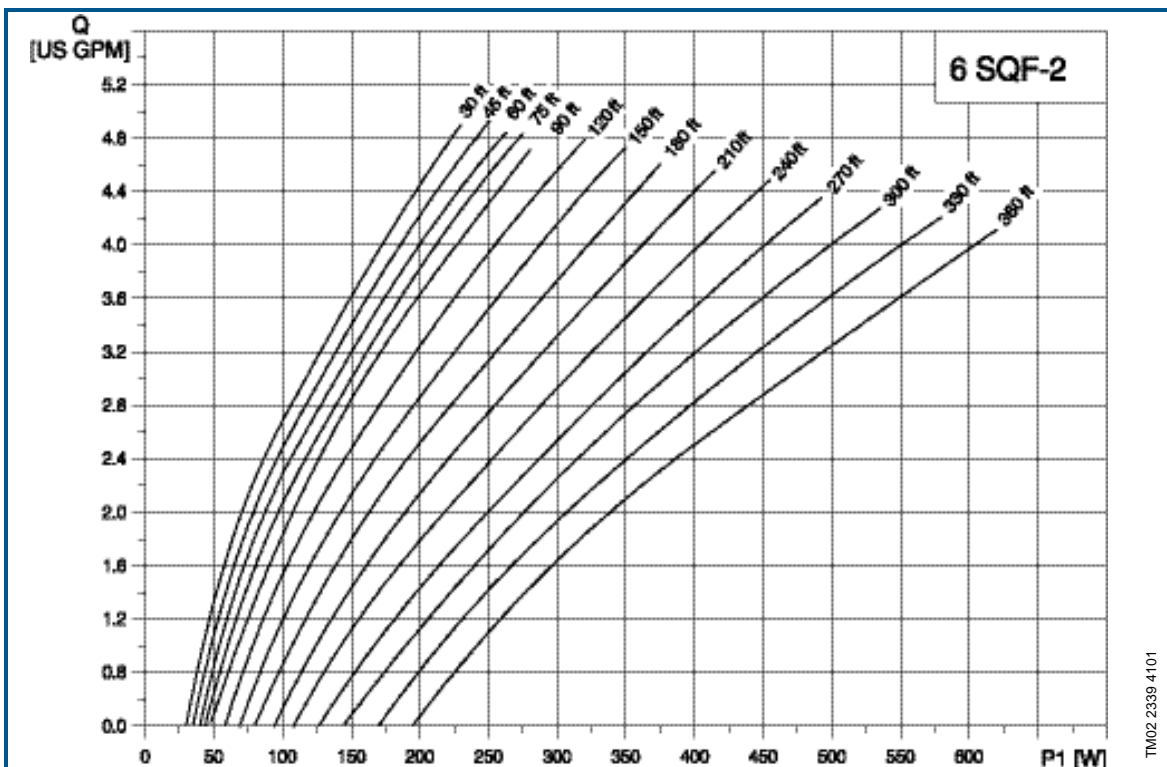

TM02 2339 4101

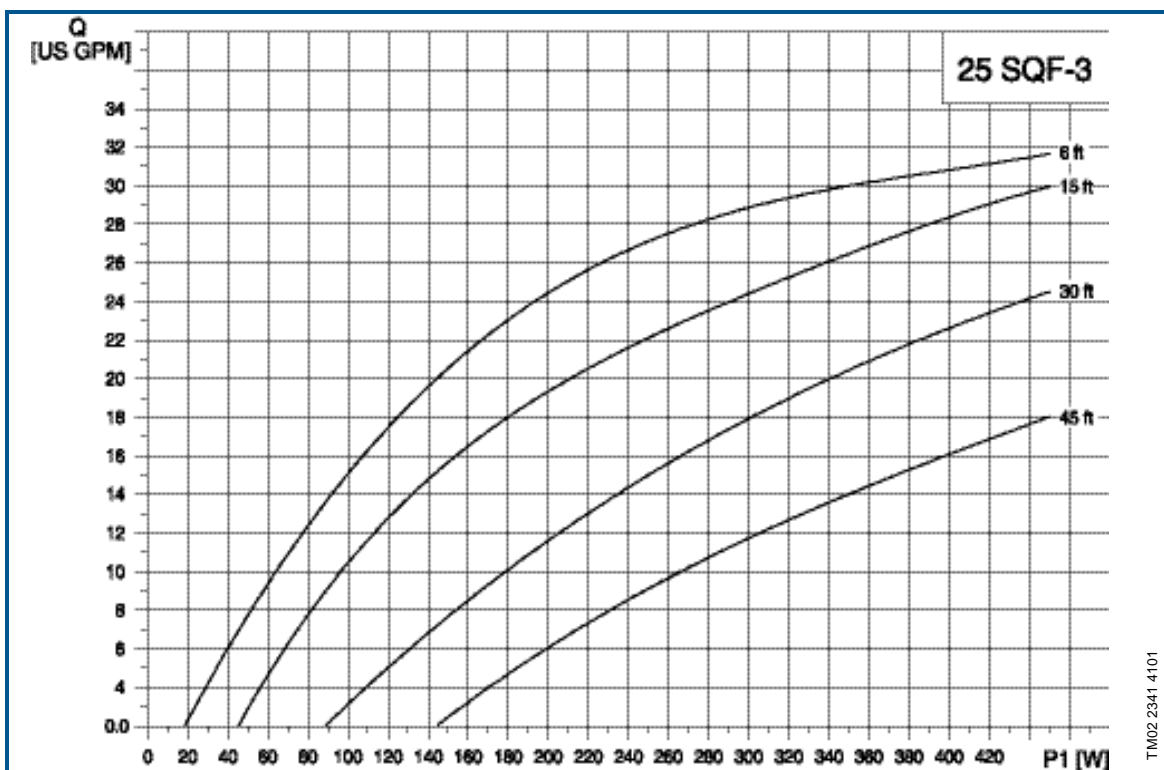
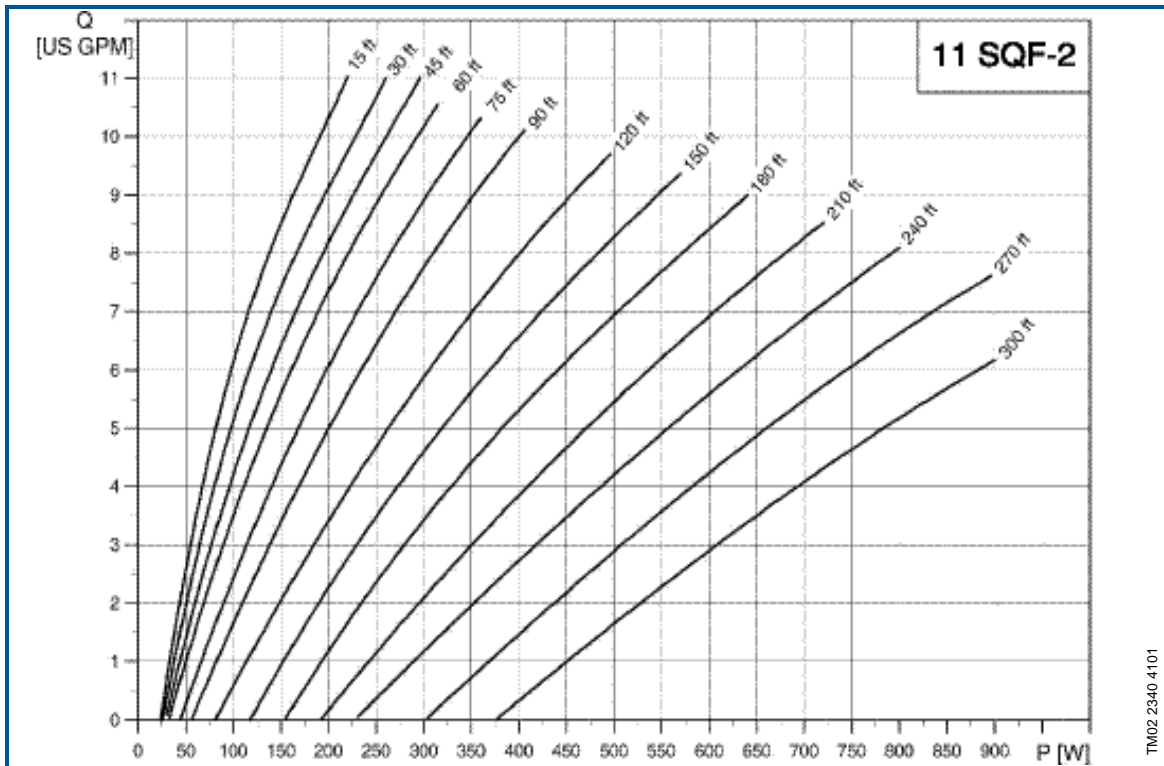

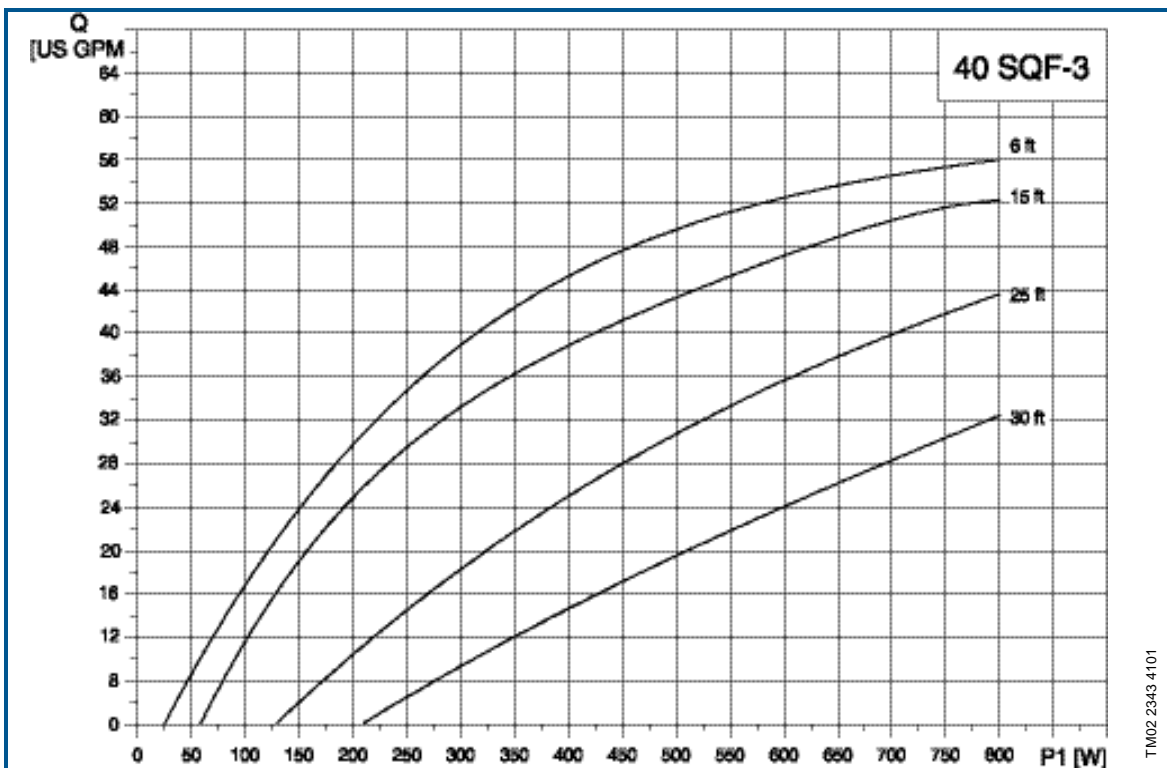
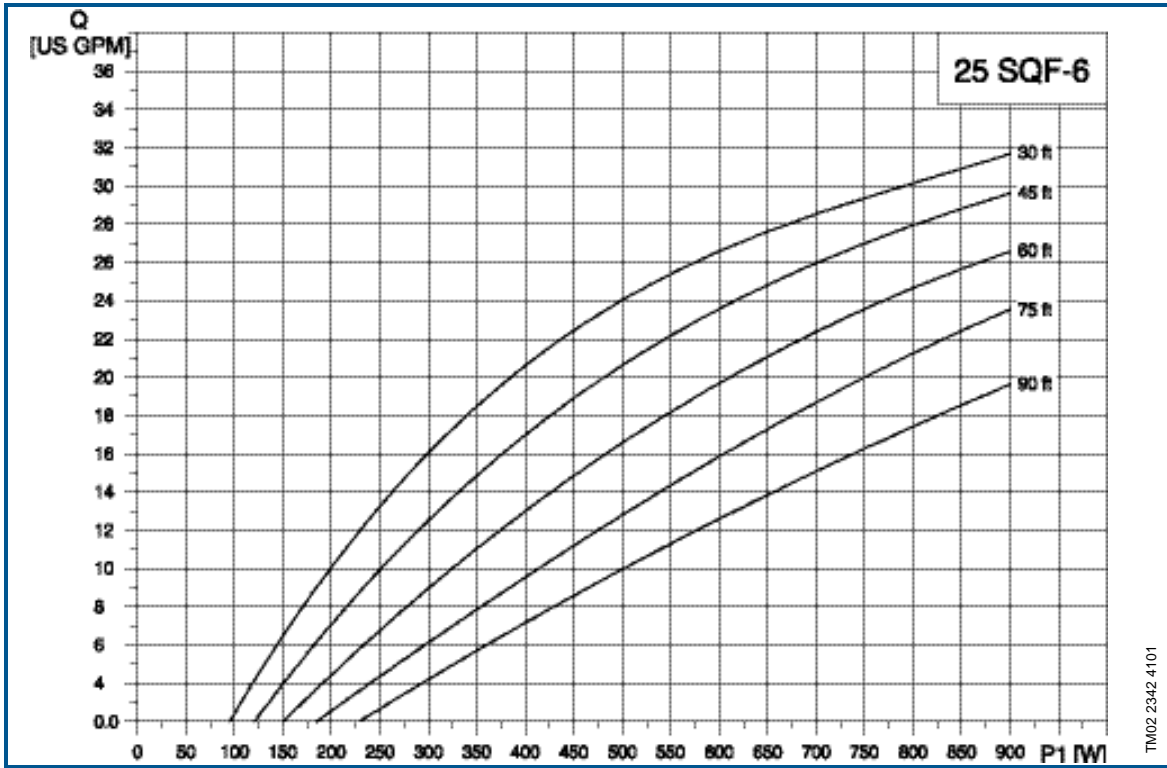

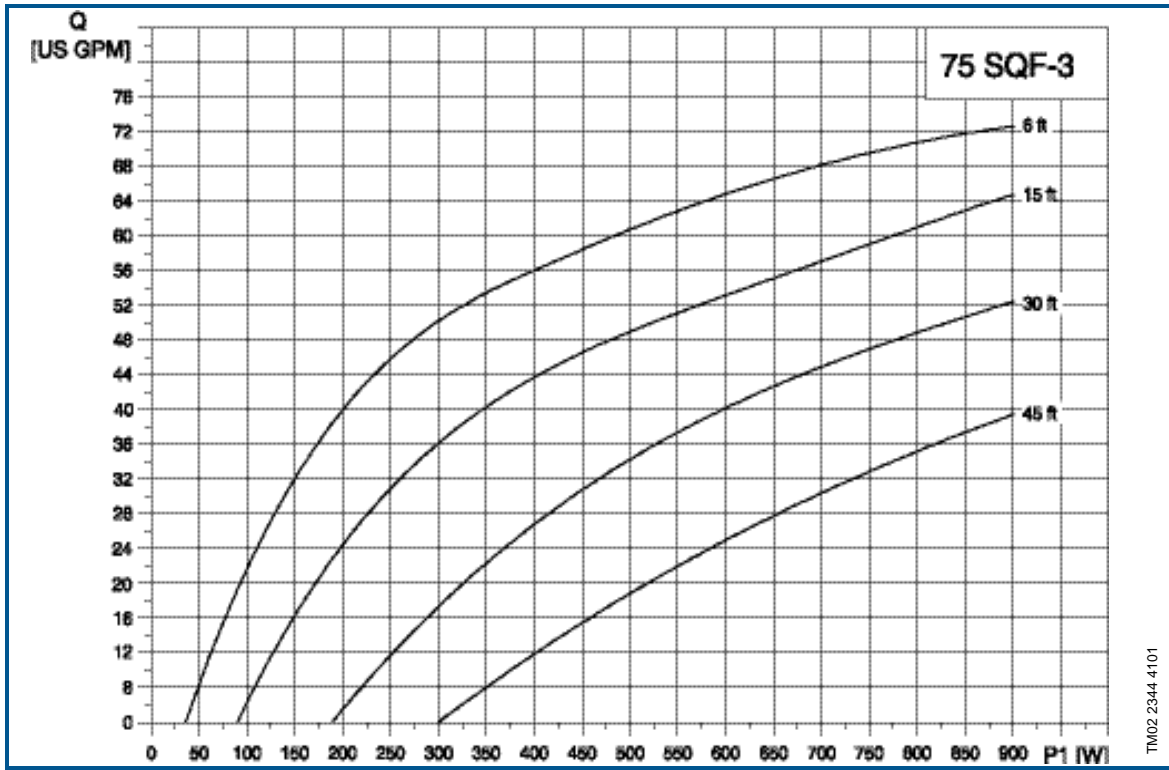

TM02 2344 4101

Dimensions and weights

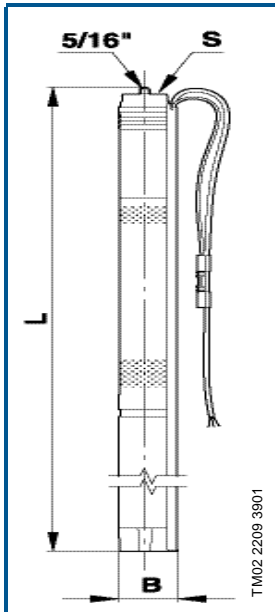

| Pump type | Dimensions [inches] | | | Net weight [LB]* | Shipping weight [LB] | Shipping Volume [ft ³] |
|-----------|---------------------|-----|--------|------------------|----------------------|------------------------------------|
| | L | B | S | | | |
| 3 SQF-2 | 47 | 3 | 1' NPT | 17 | 21 | 0.75 |
| 6 SQF-2 | 48 | 3 | 1' NPT | 17.5 | 21 | 0.75 |
| 11 SQF-2 | 49 | 3 | 1¼ NPT | 18 | 22 | 0.75 |
| 25 SQF-3 | 33 | 3.7 | 1½ NPT | 18 | 21 | 0.56 |
| 25 SQF-6 | 35 | 3.9 | 1½ NPT | 19 | 23 | 0.56 |
| 40 SQF-3 | 37 | 3.9 | 2 NPT | 21 | 24 | 0.56 |
| 75 SQF-3 | 39 | 3.9 | 2 NPT | 24 | 27 | 0.56 |

* Pump complete

Electrical data

30 - 300 VDC or 1 x 90 - 240 VAC, 50/60 Hz

SQF pump

| | |
|-------------------------------|---|
| Supply to pump | 1 x 90 - 240 V -10%/+6%, 50/60 Hz. 30 - 300 VDC. |
| Run-up time | Depending on power source. |
| Start/stop | No limitation to the number of starts/stops per hour. |
| Enclosure class | IP 68 |
| Motor protection | Built into the pump. Protection against: - Dry running by means of an external water level electrode. - Overvoltage and undervoltage. - Overload. - Overtemperature. |
| Sound pressure level | The sound pressure level is lower than the limiting values stated in the EEC Machinery Directive. |
| Radio noise | SQF comply with EMC Directive 89/336/EEC. Approved according to EN 50081-1 and 50082-2. |
| Reset function | SQF can be reset via CU 200 or by disconnecting the power from the power supply in 1 minute. |
| Power factor | PF = 1. |
| Operation via generator | Voltage: 230 VAC, -10%/+6. It is recommended that the generator output must be equal to the motor input power P ₁ [kW] plus 50%. Minimum: P ₁ [kW] plus 50%. |
| Earth leakage circuit breaker | If the pump is connected to an electrical installation where an earth-leakage circuit breaker (ELCB) is used as an additional protection, this circuit breaker must trip out when earth fault currents with DC content (pulsating DC) occur. |
| Borehole diameter | SQF 0.6, SQ 1.2, SQF 2.5: Minimum: 76 mm. SQF 5A, SQF 8A, SQF 14A: Minimum: 104 mm. |
| Installation depth | Min.: The pump must be totally submerged in the pumped liquid. Max.: 150 m below the static water table (15 bar). |
| Strainer | Holes of the strainer: SQF 0.6, SQF 1.2, SQF 2.5: ø2.3 mm. SQF 5A: ø2.5 mm. SQF 8A, SQF 14A: 4 mm x 20 mm. |
| Pumped liquids | pH 5 to 9. Sand content up to 50 g/m ³ . |
| Marking | CE |

IO 100 switch box

| | |
|---------------------|---|
| Voltage | Max. 225 VDC, 7 A. Max. 265 VAC, 7 A. |
| Enclosure class | IP 55. |
| Ambient temperature | In operation: -30°C to +50°C; during storage: -30°C to +60°C. |
| Marking | CE |

IO 101 switch box

| | |
|---------------------|---|
| Voltage | 230 VAC -15%/+10%, 50/60 Hz (internal relay). Max. 225 VDC, 7 A Max. 265 VAC, 7 A |
| Enclosure class | IP 55. |
| Ambient temperature | In operation: -30°C to +50°C; during storage: -30°C to +60°C. |
| Marking | CE |

CU 200 control unit

| | |
|------------------------------|---|
| Voltage | 30 - 300 VDC 90 - 240 VAC. |
| Power consumption | 5 W. |
| Current consumption | Max. 130 mA. |
| Enclosure class | IP 55. |
| Ambient temperature | In operation: -30°C to +50°C; during storage: -30°C to +60°C. |
| Relative air humidity | 95%. |
| Pump cable | Max. length between CU 200 and pump: 200 m. Max. length between CU 200 and level switch: 100 m. |
| Back-up fuse | Max.: 10 A. |
| Radio noise | The CU 200 complies with EMC Directive 89/336/EEC. Approved according to standards EN 55 014 and 55 014-2. |
| Marking | CE. |
| Weight | 2 kg. |

GF 43 solar module

| | |
|---|--|
| Peak power (P_{max})* | 43 Wp |
| Warranted Minimum P_{max}* | 36.7 W |
| Voltage (V_{mp})* | 141 V |
| Current (I_{mp})* | 0.31 A |
| Open circuit voltage (V_{oc})* | 196.2 V |
| Short circuit voltage (I_{sc})* | 0.42 |
| Minimum bypass diode* | 6 A |
| Minimum series fuse* | 15 A |
| Weight | 15 kg |
| Shipping volume | 0.11 m ³ (1.37 m x 0.81 m x 0.10 m) |
| Ambient temperature | -40°C to +85°C |

* Applies to a radiation of 1000 W/m² and a temperature of +25°C

Wiring diagram for pump

Connection of the MSF motor to the power supply must be done according to the wiring diagram shown below.

As the intelligent motor electronics can handle both connection possibilities, it makes no difference how the wires "+" and "-" or "N" and "L" are connected.

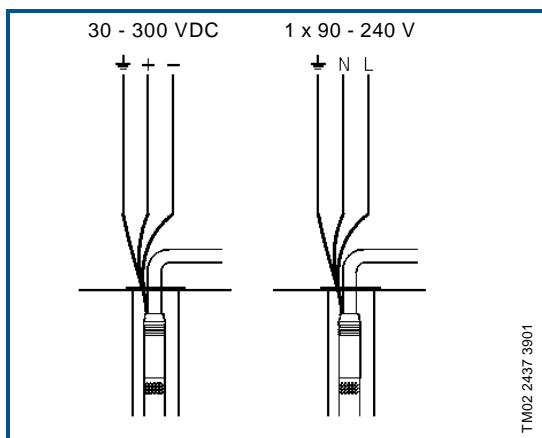

Material specification - helical rotor pump

| Pos. | Component | Material | DIN W.-Nr. | AISI |
|------|-------------------|------------------------|------------|--------|
| 1 | Valve casing | Polyamide | | |
| 1a | Discharge chamber | Stainless steel | 1.4301 | 304 |
| 1d | O-ring | NBR | | |
| 2 | Valve cup | Polyamide | | |
| 3 | Valve seat | NBR | | |
| 6 | Flange, upper | Stainless steel | 1.4301 | 304 |
| 7a | Retaining ring | Stainless spring steel | 1.4310 | 310 |
| 9 | Pump stator | Stainless steel/EPDM | 1.4301 | 304 |
| 13 | Pump rotor | Stainless steel | 1.4301 | 304 |
| 16 | Torsion shaft | Stainless steel | 1.4401 | 316 |
| 39 | Valve spring | Stainless spring steel | 1.4406 | 316 LN |
| 55 | Outer sleeve | Stainless steel | 1.4301 | 304 |
| 70 | Valve guide | Polyamide | | |
| | Cable guard | Stainless steel | 1.4301 | 304 |

Example: SQF 1.2-2

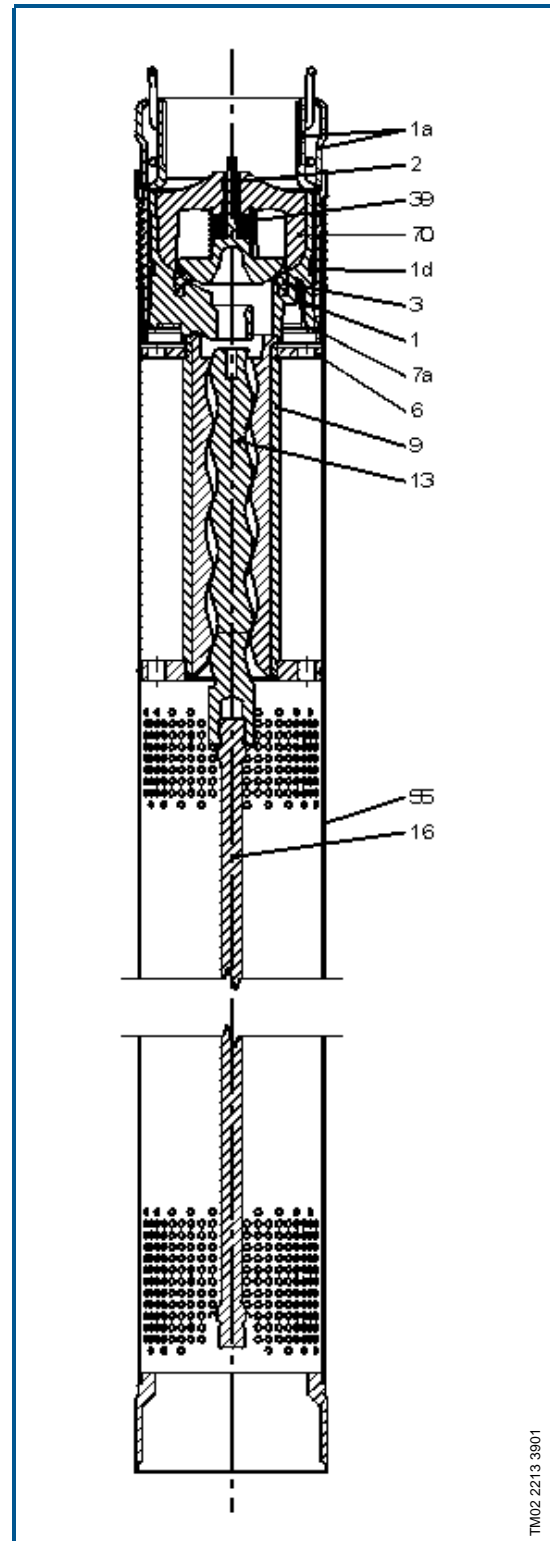

TM02 2213 3901

Material specification - centrifugal pump

| Pos. | Component | Material | DIN W.-Nr. | AISI |
|------|--|-----------------|------------|------|
| 1 | Valve casing | Stainless steel | 1.4301 | 304 |
| 1b | Discharge piece | Stainless steel | 1.4301 | 304 |
| 2 | Valve cup | Stainless steel | 1.4301 | 304 |
| 3 | Valve seat | Stainless steel | 1.4301 | 304 |
| 6 | Top bearing | NBR | | |
| 7 | Neck ring | NBR/PPS | | |
| 8 | Bearing | NBR | | |
| 9 | Chamber, complete | Stainless steel | 1.4301 | 304 |
| 10 | Bottom chamber with strainer | Stainless steel | 1.4301 | 304 |
| 13 | Impeller | Stainless steel | 1.4301 | 304 |
| 14 | Suction interconnector | Stainless steel | 1.4301 | 304 |
| 14a | Connecting piece, complete (MSF 3 adaptor) | Stainless steel | 1.4301 | 304 |
| 16 | Shaft, splined | Stainless steel | 1.4057 | 431 |
| 17 | Strap | Stainless steel | 1.4301 | 304 |
| 18 | Cable guard, pump | Stainless steel | 1.4301 | 304 |
| 18c | Cable guard, motor | Stainless steel | 1.4301 | 304 |
| 19 | Hexagon head screw for strap | Stainless steel | 1.4301 | 304 |
| 19a | Nut | Stainless steel | 1.4401 | 316 |
| 19b | Nut | Stainless steel | 1.4401 | 316 |
| 24 | Coupling with nut | Stainless steel | 1.4462 | 329 |
| 24a | Supporting ring | Stainless steel | 1.4401 | 316 |
| 24b | Spline protector | NBR | | |
| 64 | Priming screw | Stainless steel | 1.4301 | 304 |
| 70 | Valve guide | Stainless steel | 1.4301 | 304 |
| 71 | Washer | Stainless steel | 1.4301 | 304 |
| 76 | Washer | Stainless steel | 1.4301 | 304 |

Example: SQF 5A-3

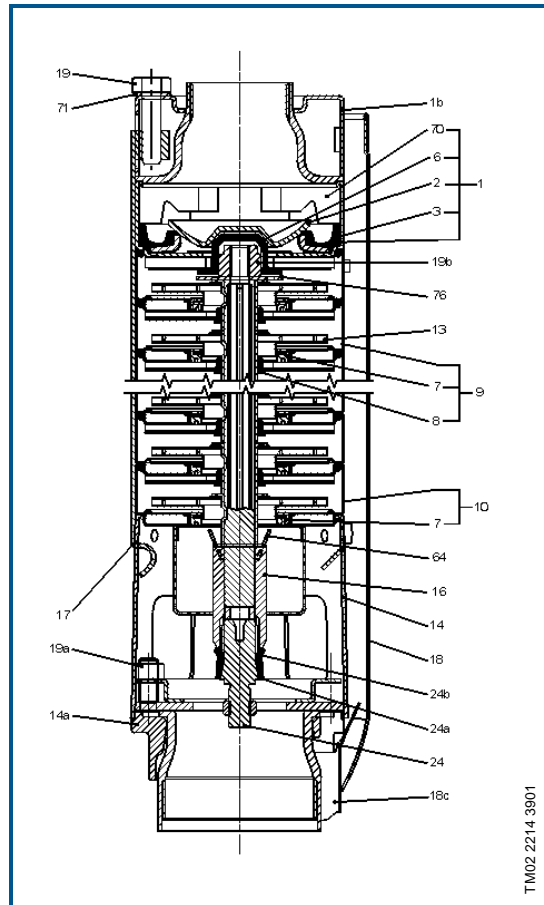

TM02 2214 3901

Material specification - motor

| Pos. | Component | Material | DIN W.-Nr. | AISI |
|------|-----------------------------|---|------------|------|
| 201 | Stator | Stainless steel | 1.4301 | 304 |
| 202 | Rotor | Stainless steel | 1.4301 | 304 |
| 202a | Stop ring | PP | | |
| 202c | Shaft end | Stainless steel | 1.4401 | 316 |
| 203 | Thrust bearing, stationary | Stainless steel/carbon | | |
| 205 | Radial bearing | Silicon carbide /tungsten carbide (sprayed) | | |
| 206 | Thrust bearing, rotating | Stainless steel/ceramic | 1.4401 | 316 |
| 220 | Motor cable with cable plug | | | |
| 222a | Filling plug | NBR | | |
| 223 | Electronic unit | | | |
| 224 | O-ring | FKM | | |
| 225 | Top cover | PPS | | |
| 232 | Shaft seal | NBR | | |
| 243 | Thrust-bearing housing | | 1.4408 | 316 |
| 250 | Nut (M4) | Stainless steel | 1.4401 | 316 |

MSF 3

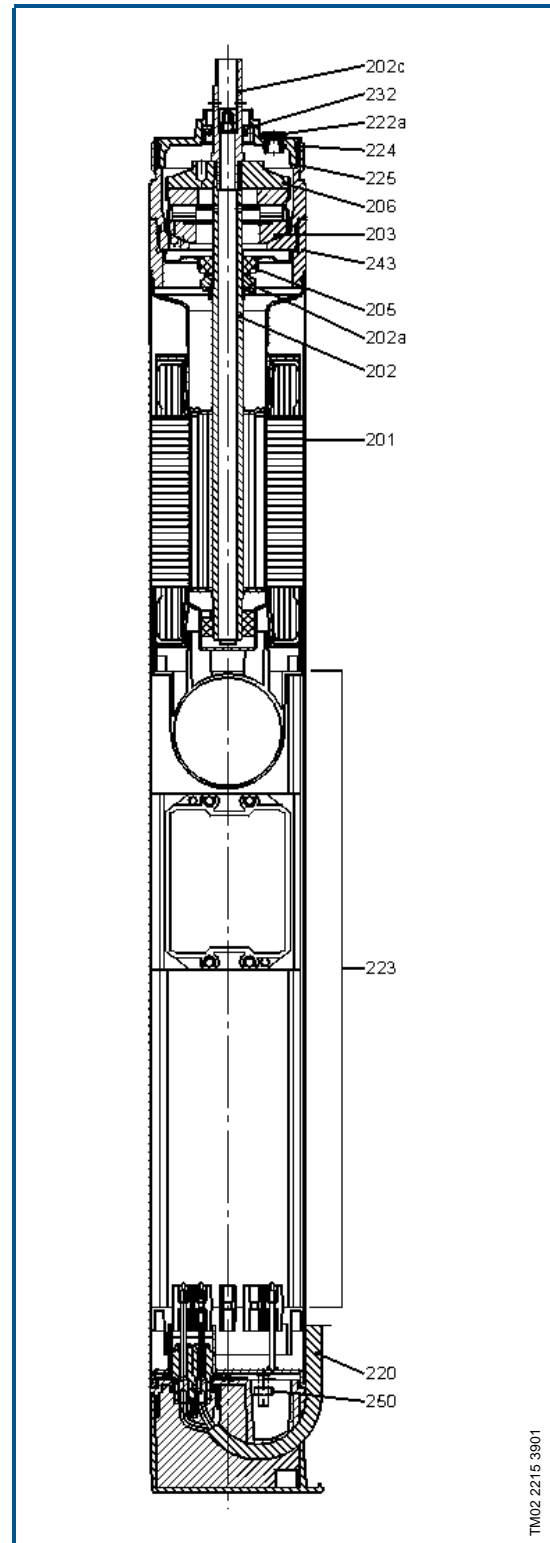

Sizing tool

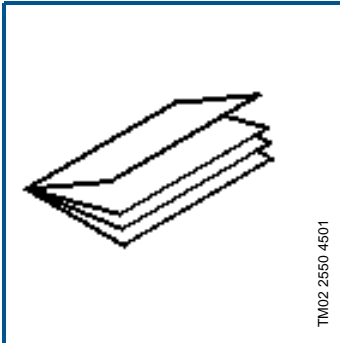

| Description | Product no. |
|--|-------------|
| Sizing tool for selection of: SQF pump and number of GF 43 solar modules. | |
| Paper version in English for: | |
| • North America. | 96 47 78 07 |
| • South America. | 96 47 78 09 |
| • Australia/New Zealand. | 96 47 78 30 |
| • Asia/Pacific. | 96 47 78 32 |
| • Southern Africa. | 96 47 78 33 |
| • Europe/Middle East/Northern Africa. | 96 47 78 34 |
| Note: The Sizing tool is also available in WinCAPS. | |

Support structure

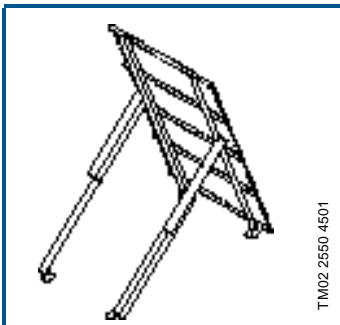

| Description | Product no. |
|--|-------------|
| Support structure for four GF 43 modules, inclusive of bolts, nuts, washers etc. Instructions are included. Note: Row closure kit is not included. | 96 47 51 00 |
| The support structure can be installed at tilt angles of 15°- 45°. | |

Row closure kit

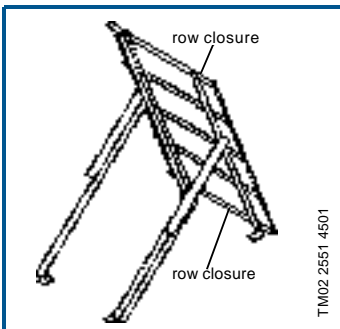

| Description | Product no. |
|---|-------------|
| Row closure kit, inclusive of ground clips and grounding terminal for four GF 43 solar modules. Instructions must be ordered together with the GF 43 solar modules. | 96 47 51 06 |
| The row closure kit is required for finishing a row of GF 43 solar modules. | |

Wire kit interpanel for GF 43

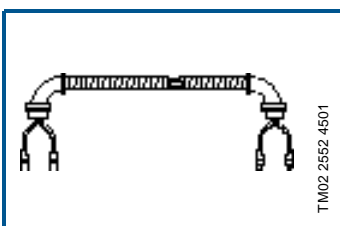

| Description | Product no. |
|--|-------------|
| Wire kit interpanel for GF 43 solar modules. | 96 47 51 04 |
| For connection of two parallel GF 43 solar panels. | |

Wire kit array to control box for GF 43

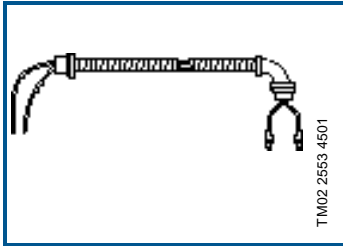

| Description | Product no. |
|---|-------------|
| Wire kit for connecting an array of solar panels to switch box/breaker box/control box for GF 43. | 96 47 51 03 |

Tower kit for H80 Whisper

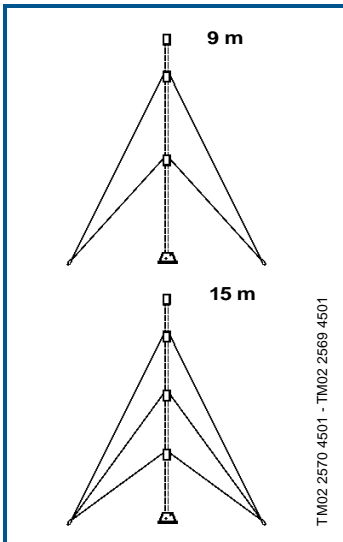

| Description | Dimension | Product no. |
|---|-----------|-------------|
| Tower kit for H80 Whisper | 30 ft. | 96 47 50 66 |
| Instruction is included. | 50 ft. | 96 47 50 67 |
| Note: The pipes are not included | | |
| For tower pipe selection see below. | | |

Tower installation kit

| Description | Product no. |
|---|-------------|
| Tower installation kit. | 96 47 50 69 |
| Note: The gin pole is not included | |
| For tower pipe selection see below. | |

Tower pipe selection

The tower kit is designed to use 2½" pipes (outside diameter of 73 mm).

The following table shows the required thickness of the pipe(s) depending on the maximum wind speed:

| Max. wind speed [m/s] | Recommended wall thickness [mm] |
|-----------------------|---------------------------------|
| 35 | 0.090 |
| 40 | 0.120 |
| 50 | 0.140 |

The wall thickness of the gin pole must be 0.060 in. or greater.

Pieces of pipe needed:

Tower kit, 30 ft.

- 1 pipe of 13 ft. for tower.
- 1 pipe of 17 ft. for tower.
- 1 pipe of 15 ft. for gin pole.

Tower kit, 50 ft.

- 2 pipes of 15 ft. for tower.
- 1 pipe of 20 ft. for tower.
- 1 pipe of 19 ft. for gin pole.

Accessories

Auger / anchor

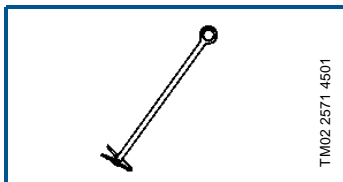

| Description | Length [in.] | Product no. |
|------------------------|--------------|-------------|
| Auger /anchor (4 pcs.) | 48 | 96 47 50 68 |

Grease

| Description | Product no. |
|--|-------------|
| Grease for lubrication of motor shaft. | 96 03 75 62 |

Level switch



| Description | Product no. |
|--|-------------|
| Level switch. High water level: Contact is closed. Low water level: Contact is open. | 00 01 07 48 |

Notes



| | |
|-------------------|-------|
| L-SP-TL-014 | 01/02 |
| PRINTED IN U.S.A. | |

Subject to alterations.

Grundfos Pumps Corporation
17100 W. 118th Terrace
Olathe, Kansas 66061
Telephone: (913) 227-3400
Fax: (913) 227-3500

