

SUNFRAME[™]**PV MODULE FRAMING
AND MOUNTING SYSTEM
FOR PITCHED ROOFS**

Add Aesthetics to the Benefits of PV Power

With your array in full view, the sunshine rule applies: it has to look good.

SunFrame delivers the visual appeal you and your neighbors expect.



To be sure, the mounting system provides structural integrity for your array. Properly installed, **SunFrame** complies with the Uniform and California Building Codes. It also meets UniRac's own high standard of installation friendliness, both initially and whenever modules need replacement.

But it is aesthetics that truly sets **SunFrame** apart. It's the only PV module mounting system designed from the outset to enhance the appearance of the home. A completed installation blends handsomely into the roof, becoming as much a part of the house as a skylight.

SunFrame Components

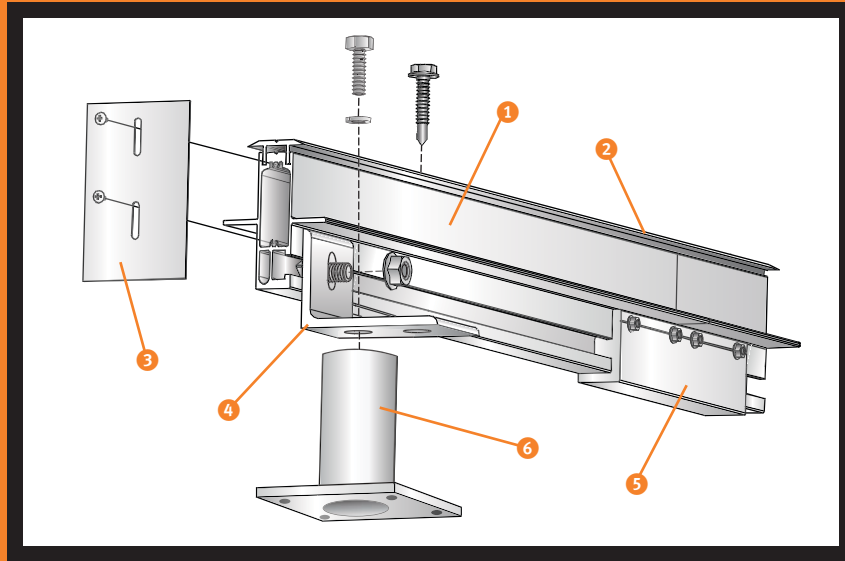

- 1 **Inter-Module Rails** provide support shelves for the modules. Depending on a module's thickness, its upper surface can be as little as 2.125 inches above the roof.
- 2 **Full Length Cap Strips** secure modules and finish the array topside forming a gap-free frame. Self-drilling screws at 16-inch intervals provide the holding power.
- 3 **End Caps** finish the rail ends to complete the frame.
- 4 **L-Feet** attach directly through asphalt shingle roofs and support the rails one-half to three-quarters of an inch above the roof surface to provide convective air flow for ventilation.
- 5 **Splices** safely extend rails.
- 6 **Standoffs** (optional), designed for standard flashing, support L-feet above tile or shake roofs. A range of heights ensure a low profile.

PV Module Compatibility List

Call UniRac or your PV dealer for any module not listed.

ASE	ASE300
AstroPower	AP100, AP110, AP165
BP Solar	3150, 3160, 4160, 5170, SX150
Evergreen	EC94, EC102, EC110
Kyocera	KC120, KC125G, KC158G, KC167G
Photowatt	PW1250, PW1650
Sharp	70, 140, 167
Shell	SP130, SP140, SP150 SQ140, SQ150, SQ160

Code Compliance

SunFrame is designed to comply with the Uniform Building Code, 1997, Chapter 16, and the California Building Code, 2001, when installed according to the SunFrame installation manual.

SunFrame Component Specifications

Rails, cap strips, splices, and L-feet: 6105-T5 aluminum extrusion.

End caps: 5052-H32 aluminum.

Standoffs: Service Condition 4 (very severe) zinc-plated welded steel.

Fasteners: 304 stainless steel.

Clear or dark finishes on all visible above-roof components, from L-feet to screw heads, match the frames of your PV modules.

www.unirac.com

For more, download *SunFrame Code-Compliant Planning and Assembly* from our SunFrame page.

10 Year Limited Product Warranty; 5 Year Limited Finish Warranty

UniRac, Inc., warrants to the original purchaser of the Product ("Purchaser") at the original installation site ("Site") that the SunFrame™ PV module framing and mounting system (the "Product") shall be free from defects in material and workmanship for a period of ten (10) years, except for the anodized finish, which shall be free from visible peeling, cracking or chalking under normal atmospheric conditions for a period of five (5) years, from the earlier of 1) the date the installation of the Product at the Site is complete, or 2) 30 days after the purchase of the Product by the original Purchaser of the Product.

The term "chalking" applies to the powdery residue formed by the breakdown of the anodized finish. It does not apply to any foreign residue deposited on the finish by the surrounding atmosphere, including, but not limited to, soot, dust, plaster, cement, etc. All installations in corrosive atmospheric conditions are excluded, including, but

not limited to chemical fumes, salt spray or surface temperatures which exceed 200 degrees F. This Warranty does not cover damage to the finish caused by moisture, condensation, or other contamination resulting from improper storage, packing or handling. The finish Warranty is void if normal maintenance and cleaning practices are not followed by Purchaser as specified by AAMA 609.93 - "Specification for Cleaning and Maintenance of Architectural Anodized Aluminum."

This Warranty does not cover damage to the Product that occurs during shipment, nor prior to installation.

This Warranty shall be void if installation of the Product is not performed in accordance with UniRac's written installation instructions for the Product, or if the Product has been modified, repaired, or reworked in a manner not previously authorized by

UniRac in writing, or if the Product is installed in an environment for which it was not designed. UniRac shall not be liable for consequential, contingent, or incidental damages arising out of the use of the Product by Purchaser.

If within the specified periods the Product shall be reasonably proven to be defective, then UniRac shall repair or replace the defective Product, or any part thereof, at UniRac's sole option. Such repair or replacement shall fulfill all UniRac's liability with respect to this limited Warranty. Under no circumstances shall UniRac be liable for special, indirect or consequential damages arising out of or related to use by Purchaser of the Product.

Typically manufacturers of related items, such as PV modules, flashings and specialized clamps, provide written warranties of their own. UniRac's limited Warranty covers only the Product, and not PV modules themselves or any other related items.