

**High-efficiency photovoltaic module using silicon nitride monocrystalline silicon cells.**

### Performance

Rated power ( $P_{max}$ )	85W
Power tolerance	$\pm 5\%$
Nominal voltage	12V
Limited Warranty <sup>1</sup>	25 years

### Configuration

<b>S</b> BP 485S	Clear universal frame with LoPro J-Box and polarized Multicontact (MC) connectors
<b>U</b> BP 485U	Clear universal frame and standard J-Box

### Electrical Characteristics<sup>2</sup>

	<b>BP 485</b>
Maximum power ( $P_{max}$ ) <sup>3</sup>	85W
Voltage at Pmax ( $V_{mp}$ )	17.8V
Current at Pmax ( $I_{mp}$ )	4.9A
Warranted minimum $P_{max}$	80.75W
Short-circuit current ( $I_{sc}$ )	5.4A
Open-circuit voltage ( $V_{oc}$ )	22.0V
Temperature coefficient of $I_{sc}$	(0.065 $\pm$ 0.015)%/ °C
Temperature coefficient of $V_{oc}$	-(80 $\pm$ 10)mV/°C
Temperature coefficient of power	-(0.5 $\pm$ 0.05)%/ °C
NOCT (Air 20°C; Sun 0.8kW/m <sup>2</sup> ; wind 1m/s)	47 $\pm$ 2°C
Maximum series fuse rating	15A (S,L) 20A (U)
Maximum system voltage	600V (U.S. NEC rating) 1000V (IEC & TÜV Rheinland rating)



### Mechanical Characteristics

Dimensions **S,U** Length: 1209mm (47.6") Width: 537mm (21.1") Depth: 50mm (2.0")

Weight **S,U** 7.7kg (17.0 pounds)

Solar Cells **S,U** 36 cells (125mm x 125mm) in a 4x9 matrix connected in series

Output Cables **S** RHW AWG# 12 (~4mm<sup>2</sup>) cable with polarized weatherproof DC rated Multicontact connectors; asymmetrical lengths - 900mm (-) and 800mm (+)

Junction Box **U** Type A junction box with 6-terminal connection block; IP 54, accepts PG 13.5, M20, ½ inch conduit, or cable fittings accepting 6-12mm diameter cable. Terminals accept 2.5 to 10mm<sup>2</sup> (8 to 14 AWG) wire.

Diodes **S,U** Two 9A, 45V Schottky by-pass diodes included

Construction **S,U** Front: High-transmission 3mm (1/8<sup>th</sup> inch) tempered glass; Back: Tedlar; Encapsulant: EVA

Frame **S,U** Clear anodized aluminum alloy type 6063T6 Universal frame; Color: silver

1. Module Warranty: 25-year limited warranty of 80% power output; 12-year limited warranty of 90% power output; 5-year limited warranty of materials and workmanship. See your local representative for full terms of these warranties.
2. These data represent the performance of typical BP 485 products, and are based on measurements made in accordance with ASTM E1036 corrected to SRC (STC.)
3. During the stabilization process that occurs during the first few months of deployment, module power may decrease by up to 3% from typical  $P_{max}$ .

## Quality and Safety

<b>ESTI</b>	Module power measurements calibrated to World Radiometric Reference through ESTI (European Solar Test Installation at Ispra, Italy)
<b>CE</b>	Manufactured in ISO 9001-certified factories; conforms to European Community Directives 89/33/EEC, 73/23/EEC, 93/68/EEC; certified to IEC 61215
<b>TUV</b>	Framed modules certified by TÜV Rheinland as Safety Class II (IEC 60364) equipment for use in systems up to 1000 VDC
<b>UL</b>	Listed by Underwriter's Laboratories for electrical and fire safety (Class C fire rating)
<b>FM</b>	Approved by Factory Mutual Research in NEC Class 1, Division 2, Groups C & D hazardous locations (U)

## Qualification Test Parameters

Temperature cycling range	-40°C to +85°C (-40°F to 185°F)
Humidity freeze, damp heat	85% RH
Static load front and back (e.g. wind)	50psf (2400 pascals)
Front loading (e.g. snow)	113psf (5400 pascals)
Hailstone impact	25mm (1 inch) at 23 m/s (52mph)

## Module Diagram

Dimensions in brackets are in inches. Un-bracketed dimensions are in millimeters. Overall tolerances  $\pm 3\text{mm}$  (1/8")

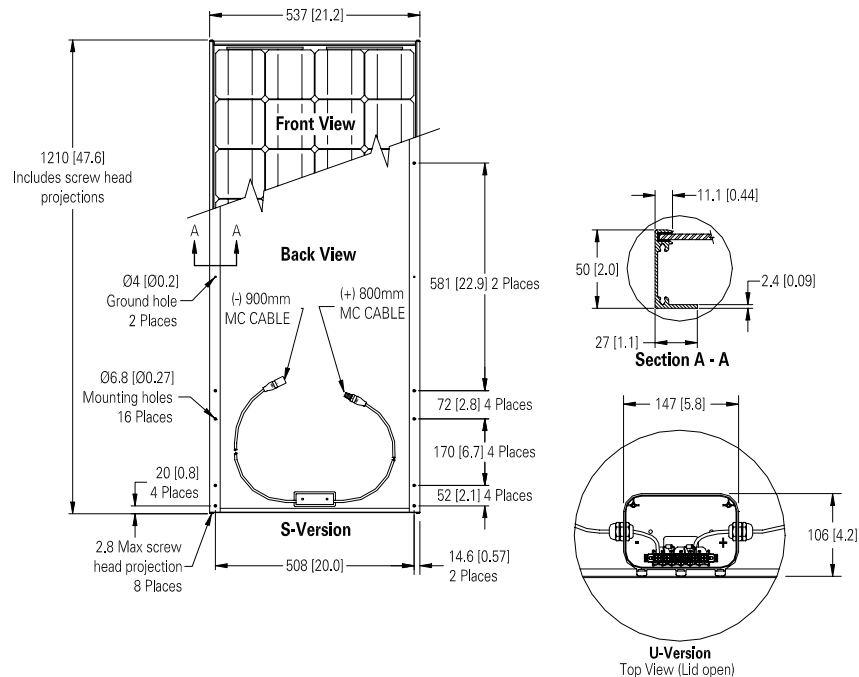

## BP 485 I-V Curves

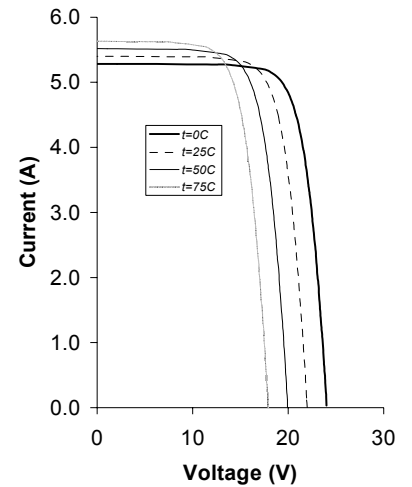

Self-tapping grounding screw, instruction sheet, and warranty document included with each module.

**Note:** This publication summarizes product warranty and specifications, which are subject to change without notice. Additional information may be found on our web site: [www.bpsolar.com](http://www.bpsolar.com)