

# Roof Trac™ PV MOUNTING SYSTEM INSTALLATION MANUAL

Patent #6,360,491

The **ROOF TRAC™** PV mounting system makes the installation of PV modules for rooftop installations easy, safe and attractive. The patented (pat #6,360,491) PV support mount along with the **TILE TRAC®** patented (pat #5,746,029) tile roof attachment system, is used to install frame modules to the most common roof tops including concrete tile. This manual will illustrate the proper installation of the **TILE TRAC®** system and provide the installer general information on roof framing and roof coverings. This manual will also provide instruction on how to make solid, leak free attachments to the roof.

This manual will be divided into 9 different sections to provide the new and experienced installer general information and techniques that will reduce labor costs while providing a safe structural attachment to the roof. The instruction guide is divided into the following areas:

- Components of the **ROOF TRAC™** PV mounting system
- General information about roof framing and coverings
- How to locate rafters
- Installation of modules using the **TILE TRAC®** base on composition roofs
- Installation on new construction or new roof using the **FASTJACK®** flashable roof support stanchion
- Attachment of the modules to the support channel
- Installation of the **TILE TRAC®** system for tile roof installations
- Safety guidelines for the solar installer
- Recommended tools

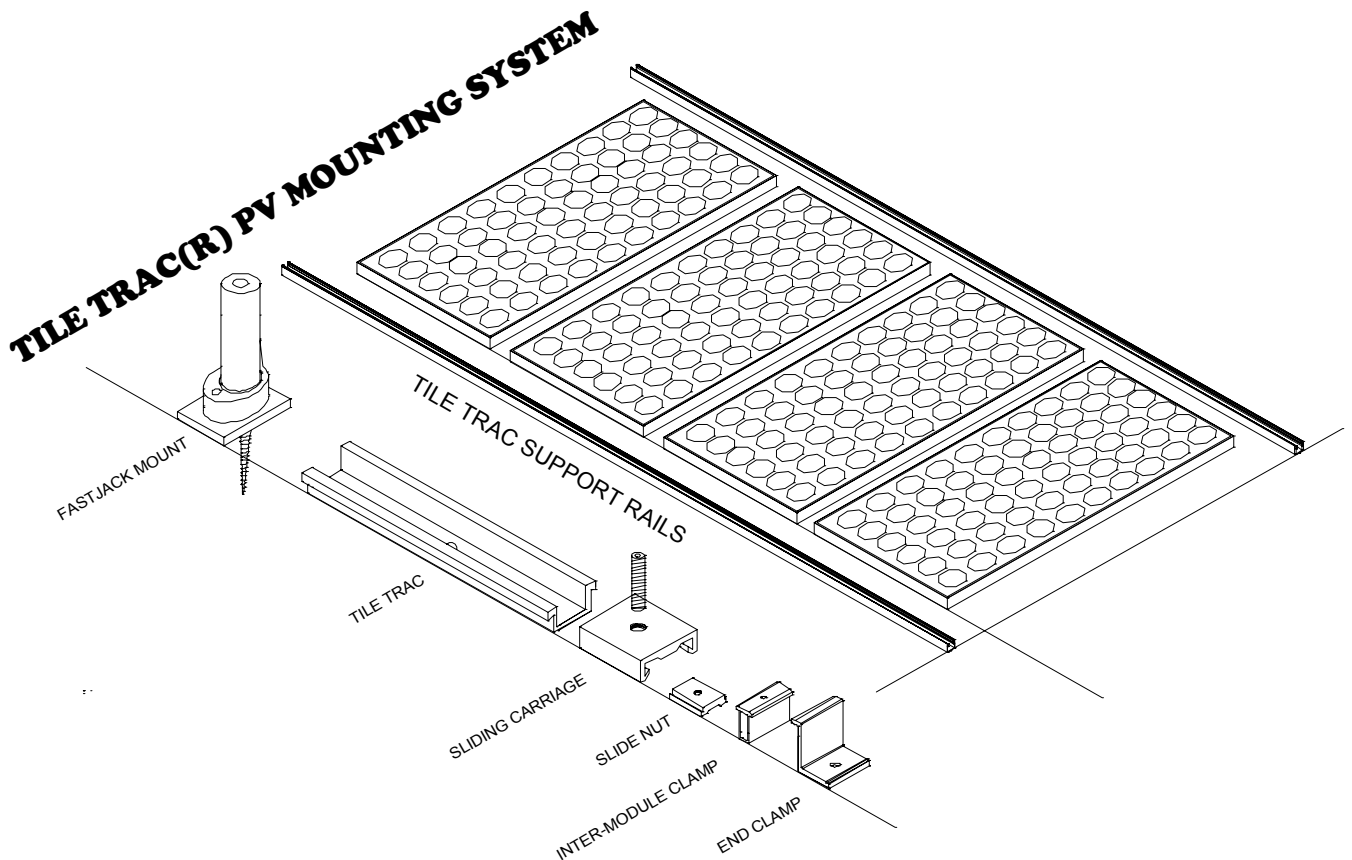

# TILETRAC® & FASTJACK® MOUNT COMPONENTS

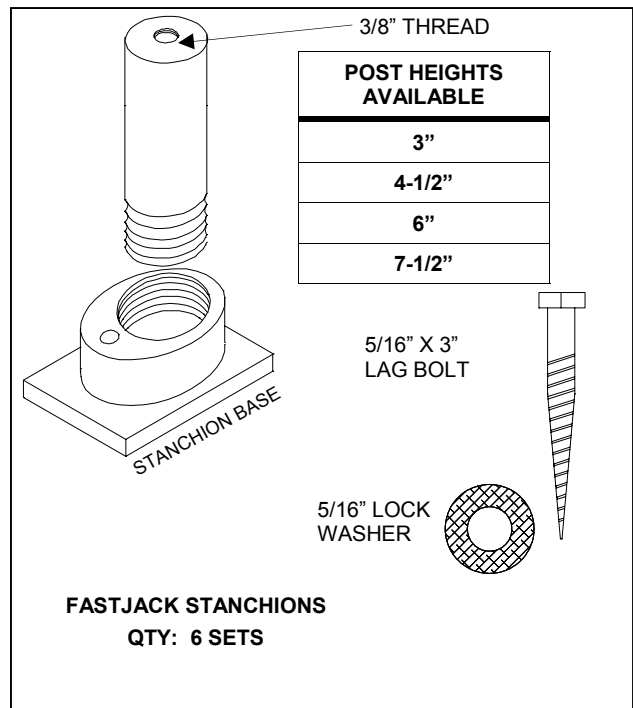
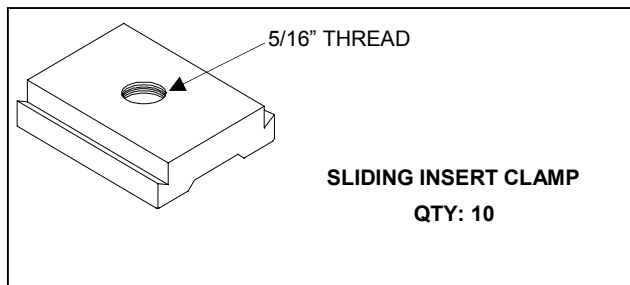
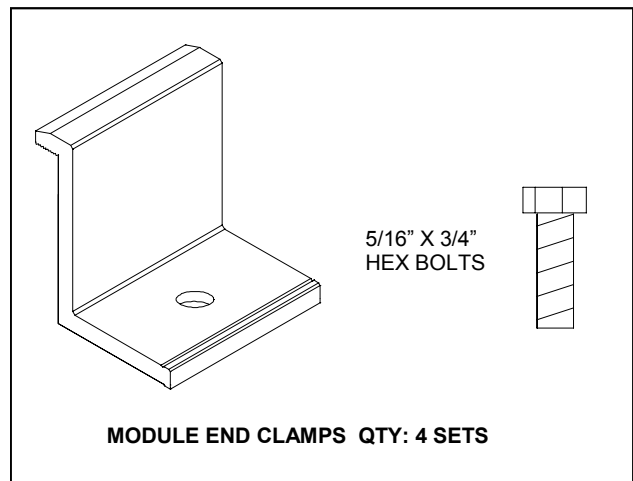
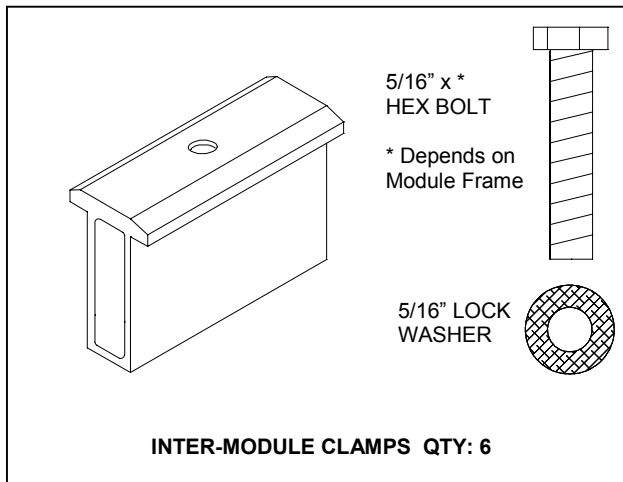
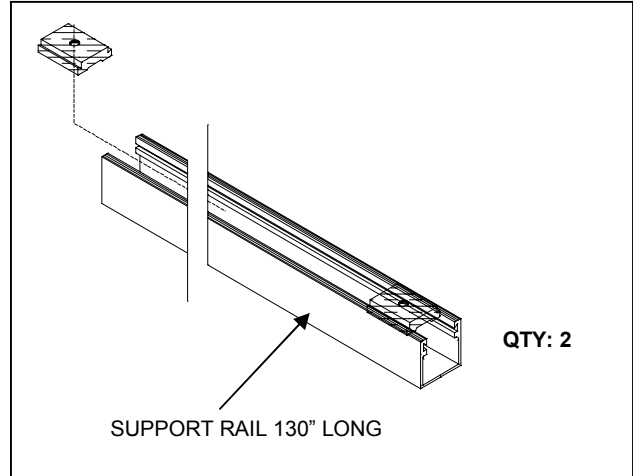
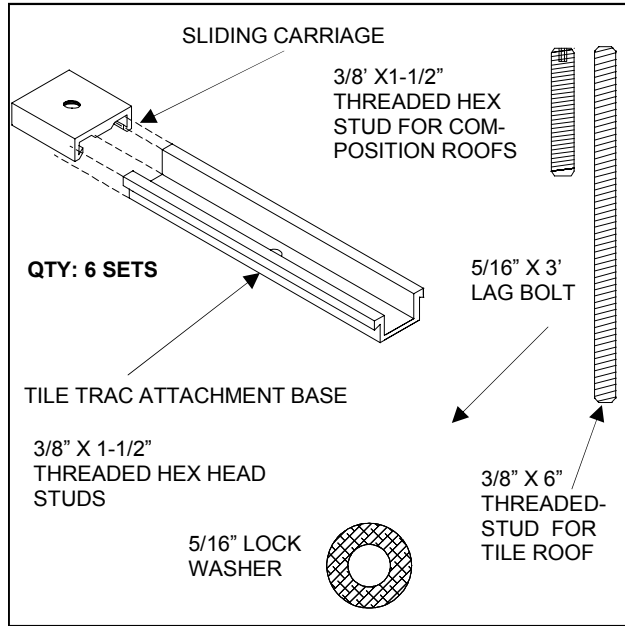

# ROOF CONSTRUCTION

**SOLAR** modules of any type must be structurally attached to the roof. This means that they must be secured (bolted) into a structural member of the roof such as a rafter or joist. Structural attachment prevents damage resulting from wind, earthquakes and snow loading, it also insures that the penetration into the roof will be sealed and compressed to provide a leak free connection for the life of the system.

The **TILE TRAC® PV** mounting system's patented design has been specially engineered and tested to meet industry requirements for load testing and engineering. The **TILE TRAC®** mount system has been load tested and approved by a licensed structural engineer. (Copies of engineering reports are available with purchase). **TILE TRAC®** mounts are load tested in both the uplift and download conditions while under load at 50 pounds per square foot. Our unique extruded support rail design accomplishes this degree of support with minimal deflection using relatively light gage aluminum.

This **TILE TRAC®** system was the first system to employ the benefit of the "top down" attachment method. This unique innovation allows the installers to properly install attachment bolts into rafters. Before the invention of this product all module systems had to be bolted from the rear of the module frame. All module clamp sets and engineering are "module specific" and are tested and sized appropriately for each module manufacturer.

The following sections of this manual will provide a good general knowledge of most likely roof installation situations. It is presumed that the installer has a fundamental knowledge of roof construction and tools. We will also try to suggest ways in which you can reduce installation labor and time. We appreciate your selection of our mounting system and hope that this installation guide will make your installation experience faster and more profitable.

**Safety:** Installers should use only approved ladders and work only when roofs are dry and avoid installation on windy days. Secure all tools, modules and parts to prevent them from falling off the roof. It is advised to protect all exposed studs with protective caps during the installation process to prevent injury.

## GENERAL ROOF TYPES:

**Rafter and Pitch:** Most modern roofs are composed of structural framing which consists of rafters or trussed units. Rafters are usually 2"x6" or better and are usually found in custom construction. Trusses are geometric shapes that are pre-fabricated in a factory

and brought to the construction site. Trusses are generally used in track or modular homes. Each of these roof supports systems will work exactly the same for attachment of the **TILE TRAC®** system. The angle (inclination) of the roof is measured in terms of a division of 12, examples would be "3 in 12" "4 in 12" "5 in 12", this simple means the height is relative the horizontal measure. Most roof pitches will fall the previous categories. For the sake of this manual we will consider all roof supports rafters.

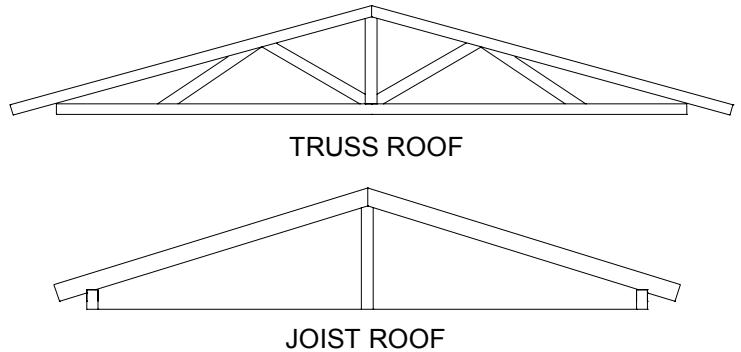

Rafter spans are generally 12", 16" or 24" O/C (on center). All modern roofs are design to support plywood centers which are 48". For this reason the **TILE TRAC® PV** mounting system is engineered and tested at 48" centers for both portrait and landscape configurations. All attachments to the roof should be laid out and attached at 48" centers, attaching at this common distance and you will be reasonably assured of making a structural attachment to a roof rafter, while distributing the load evenly on the roof structure.

**Sheathing:** Roof covering over the rafters generally consist of three types of materials;

1. Exterior roofing plywood.
2. OSB which is an abbreviation for Oriented Strand Board, this material has now become the standard for new home construction. This material consists of pressed wood fibers which looks similar to particle board. Although this material is structurally sound for roof sheathing, it does not have the ability to secure a lag bolt if the rafters are missed.
3. Skip sheathing (space sheathing): This material is generally not used anymore because of more strict fire codes. This is simply a 1" x 4" or better nailed to the rafters with a space or gap between each board. This type of support is mainly used on older shake or wood shingle roofs.

**Important:** Attaching or bolting to sheathing is not generally considered a structural attachment and should be avoided.

# TECHNIQUES FOR LOCATING THE ROOF RAFTERS

Based upon the fact that roof rafters can be located at 48" centers, becomes necessary to properly locate at least one rafter. After locating a rafter, it can be used to reference other rafters on the roof. Since the roof sheathing and roofing materials conceal the rafters, there are several techniques that can be used to locate the rafter centers. Keep in mind that the rafter must be located absolute center for proper attachment. Rafters will generally provide a target of 1-1/2" wide which makes accurately locating the rafter is important for proper attachment.

Regardless of the actual spacing of the rafters, most can be located at 48" centers. Here are some ways to accomplish this.

1. If the roof eve is exposed, use a framing square to locate the rafter tail and carefully transfer this location to the edge of roof. Mark this location with a crayon, visible from the top of the roof. Reference this measurement to the edge of the gable. Transfer this measurement to the work area and you should be fairly close to the rafter. For a hip roof you will have to estimate the rafter location by visually triangulating the location perpendicular to the eve. If the roof has a closed or blind soffet, you can visually look for the nails on the rim joist (fascia board), this will indicate the general location of the rafter.
2. Composition shingle or rolled cap sheet: Once you have general idea were the rafter is, you can refine your search by several methods. One simple method is to use a smooth face hammer (a rawhide hammer works nice here) and lightly tap perpendicular to the rafter until you hear a solid sound. Mark this location and you should be within inches of the rafters absolute center location. To determine absolute center you can drill small holes either left or right of the rafter until you hit the rafter center. Another way is to use a high density electronic stud sensor at the "HIGH RANGE" setting. Carefully sliding the device over a piece of thin cardboard (allowing it to slide off the roof shingles) will accurately show the start and ending location of the rafter.
3. Tile roof rafter location: This will consist of estimating the general location of the rafter and then removing the tile in the vicinity of it. After removing the tile, use the same procedures as above.
4. After locating the center of the rafter, it is advisable to mark the hole using a crayon. Important! Never leave a hole unmarked or unaccounted for.

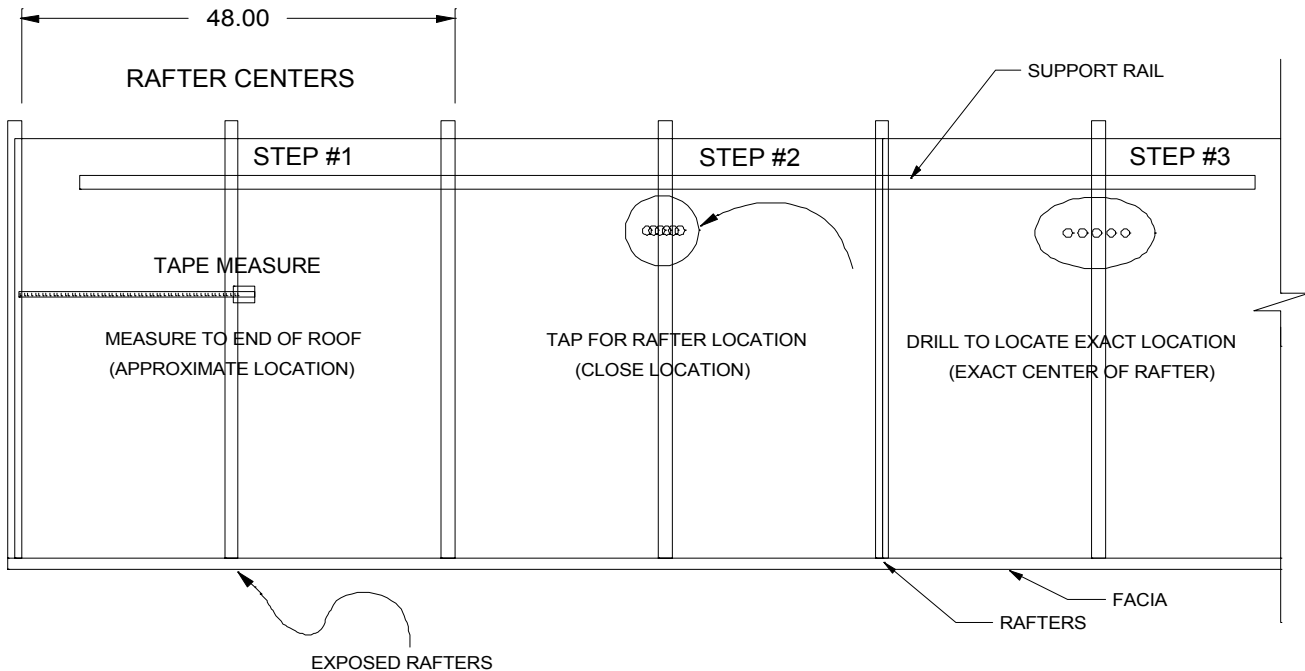

LOCATING RAFTER FOR DRILLING AND SUPPORTING ATTACHMENTS

## INSTALLING THE *TILE TRAC*® ATTACHMENT FEET

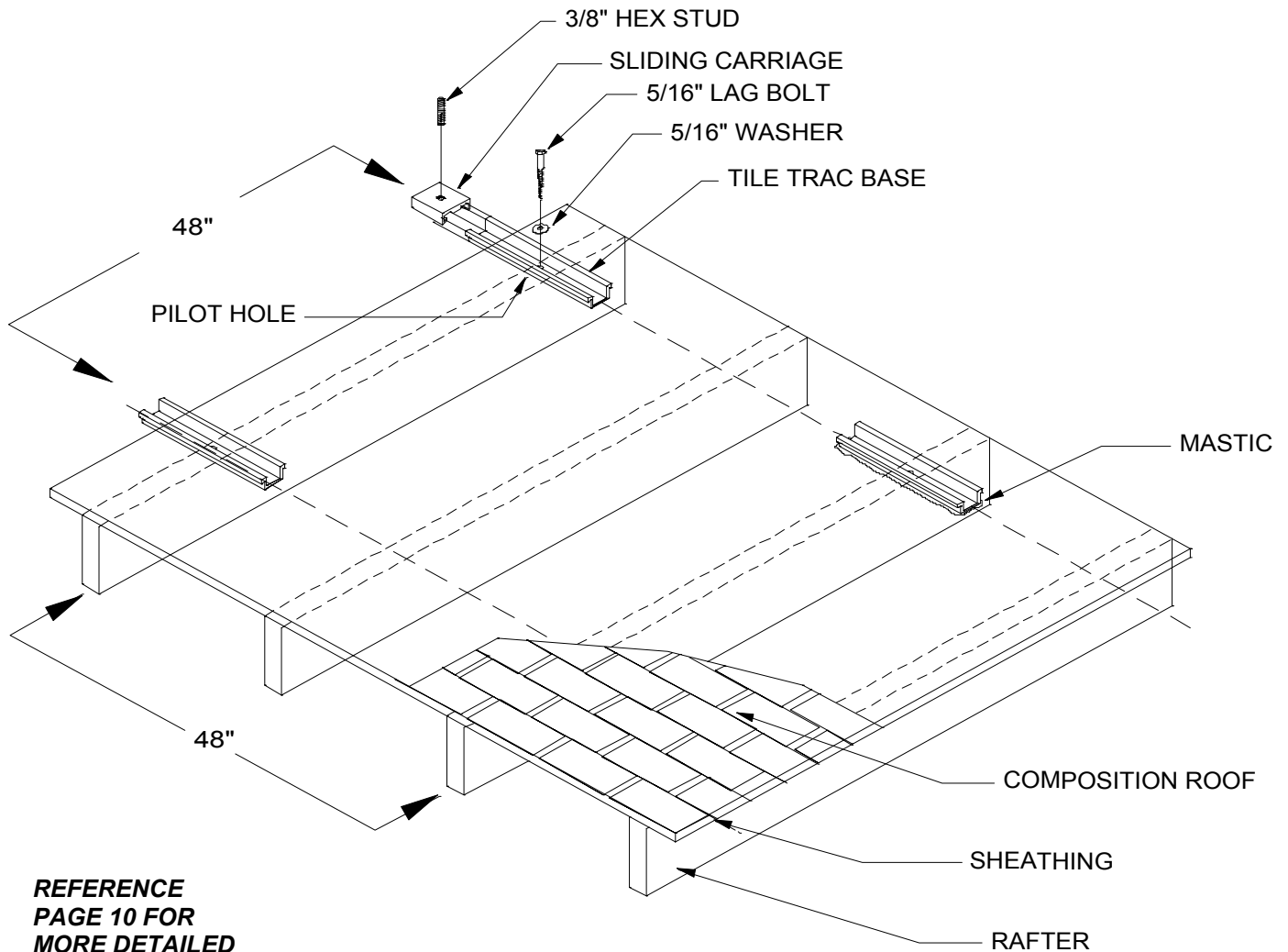

**REFERENCE  
PAGE 10 FOR  
MORE DETAILED  
INSTALLATION  
INSTRUCTIONS.**

### How to attach the *TILE TRAC*® base to the roof.

After locating the exact position for the *TILE TRAC*® bases, drill a 3/16" (we recommend a carbide masonry bit) pilot hole into the rafter, place the lag bolt and washer through the base and apply mastic or roof sealant to the bottom of the base extrusion. Insuring that the roof is clean and warm, install base by inserting the lag bolt into the hole

and impacting the lag bolt down using a 1/2" drive socket (do not over-tighten). After the base has been secured and sealed to the roof, install the sliding carriage over the base and thread in the 3/8" hex stud. At this point, leave the carriage stud loose to allow for final adjustment. Continue installing the *TILE TRAC*® six attachment feet per rail set installed on 48" centers.

## INSTALLATION OF THE *ROOFTRAC*® SUPPORTS TO THE ROOF MOUNTS

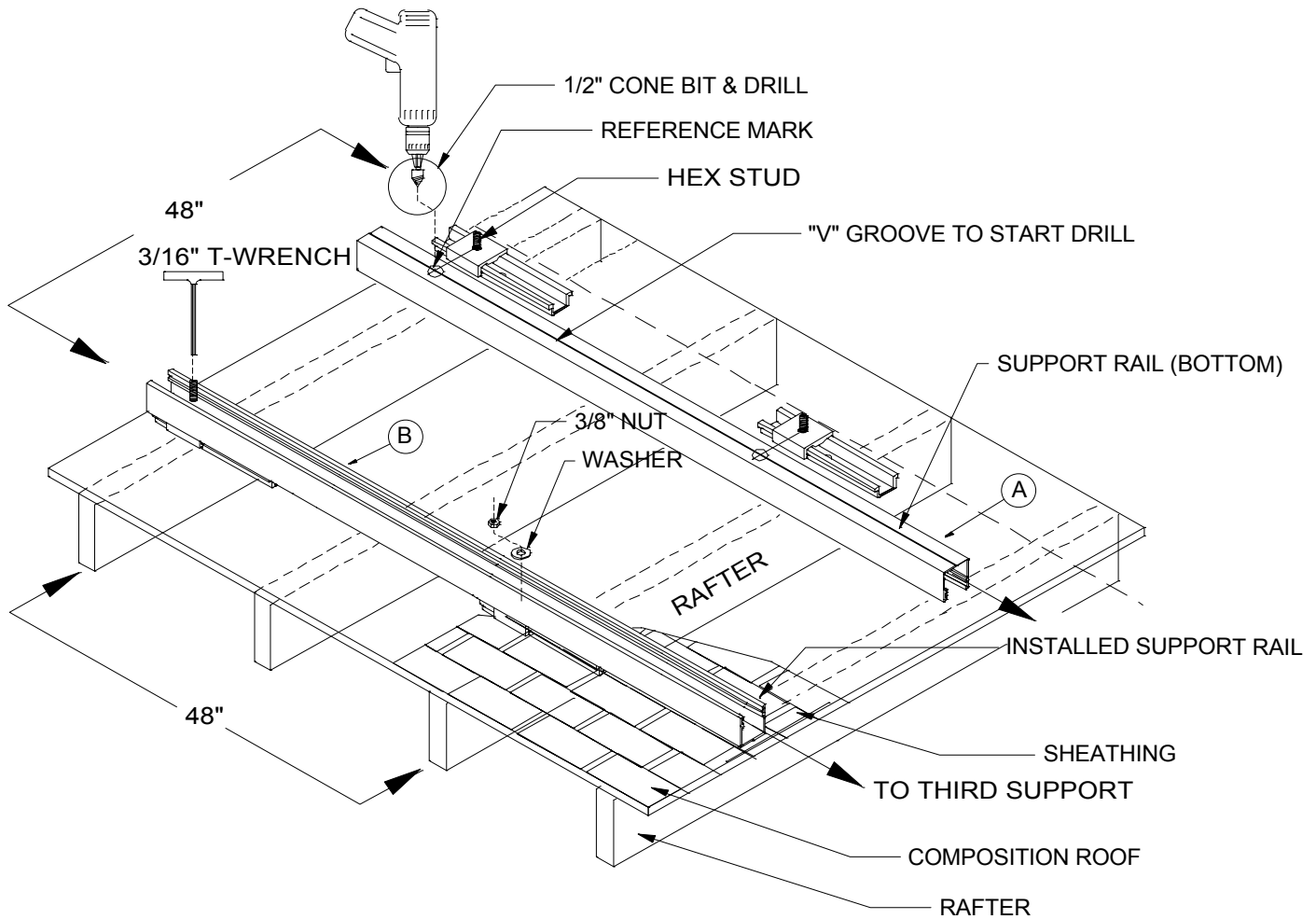

### Installation of the *ROOFTRAC*® support rails to the attachment feet.

After the base has been secured and sealed to the roof, install the sliding carriage over the base and thread in the 3/8" short hex stud. At this point, leave the carriage stud loose to allow for final adjustment. Continue installing the sliding carriages over the *TILE TRAC*® bases, 6 sets are required per set of module supports.

Lay the module supports (upside down) next to the *TILE TRAC*® supports as illustrated in fig. "A" above. Mark the

channel adjacent to the support feet. Align and mark the intersecting "V" groove on the rail and drill a 1/2" hole through the rail. (Note: a "Uni-Bit™" sheet metal cone bit is recommended for this). After drilling the hole in the support rail, place the rail over the attachment feet (fig. "B"), make any necessary final adjustments and tighten the carriage using a 3/16" hex wrench. After the stud has locked the carriage to the *TILE TRAC*® base, install the 3/8" washer and nut and tighten using a 9/16" deep socket wrench. Your support rails are now secure and ready for installation of the modules.

## INSTALLATION OF THE MODULES OVER THE *ROOF TRAC*® SUPPORT RAILS

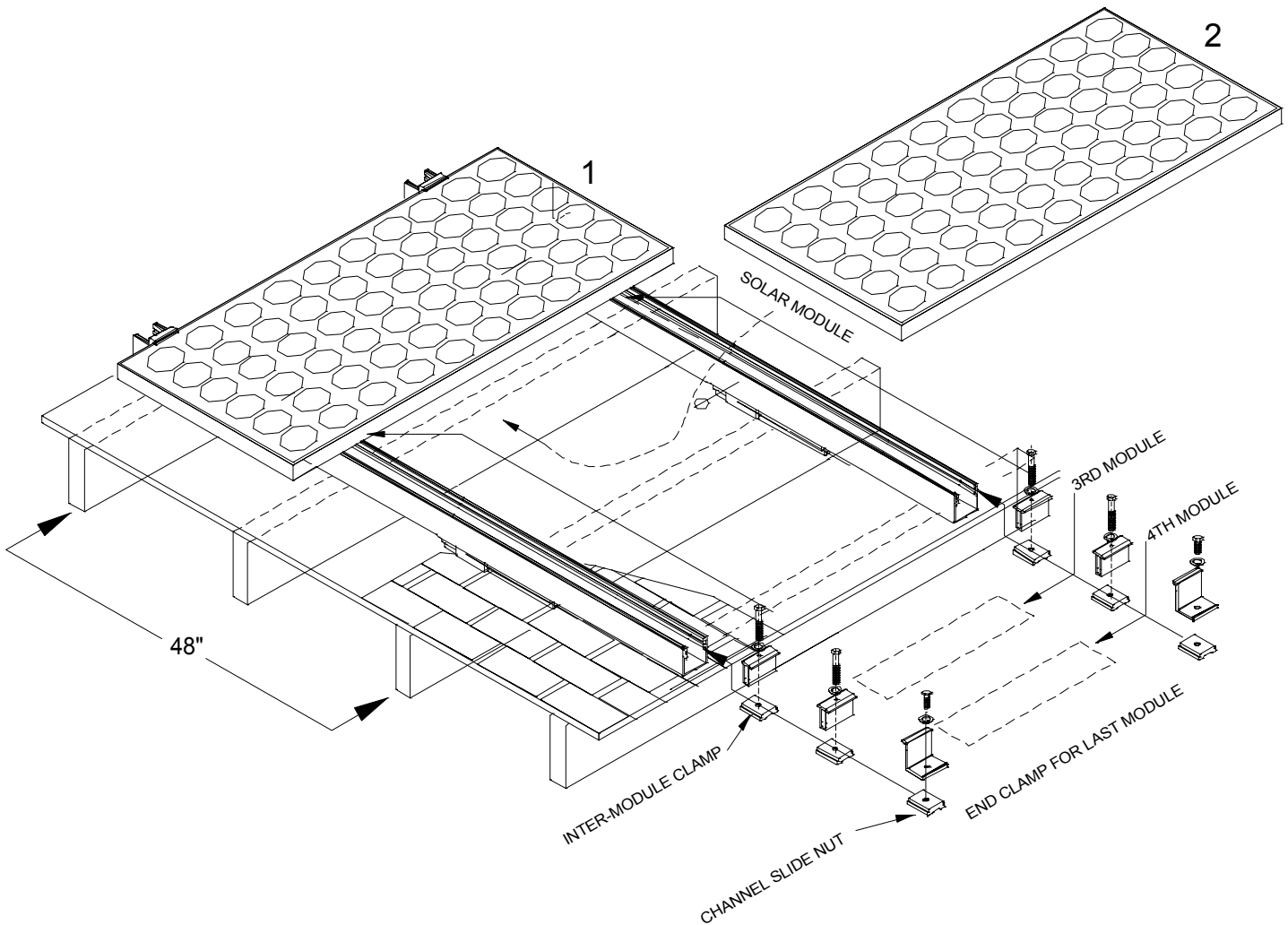

Attachment and clamping of the solar modules to the **TILETRAC**® feet or **FASTJACK**® stanchions work exactly the same. After the support rails have been installed to the attachments, you are now ready to install the solar modules. There are two sets of clamps; the outside clamps (end clamp) and the inter-module clamps that install between the modules. For convenience, it is advisable to pre-thread or start the bolt, lock washer and clamp into the sliding insert prior to bringing them up to the roof. Slide the two end clamps near the end of the support rail and install your end module (first). Carefully square the module to the frame and tighten the clamps using a 1/2" box wrench or drive socket. **DO NOT OVER-TIGHTEN**, we recommend a maximum torque of 20 foot pounds to prevent damage to the module glass. After the first module is secured, slide two inter-module

clamp sets onto the first module. They are designed to stay in place freeing you up to slide and align the next module into place. Repeat this procedure until all modules are installed onto the support rail. Upon installation of the last module in the panel, install the module end clamp to complete the installation.

Please note that all module end clamps are proprietary and specially extruded to fit a specific brand of module. Since many of these tolerances are very small, we install a die line (marker) to differentiate the correct die per module frame. Please refer to the module end clamp illustration on page 2 to insure you are using the correct end clamp.

# ROOF INSTALLATION FOR THE FASTJACK® FLASHABLE SUPPORTS

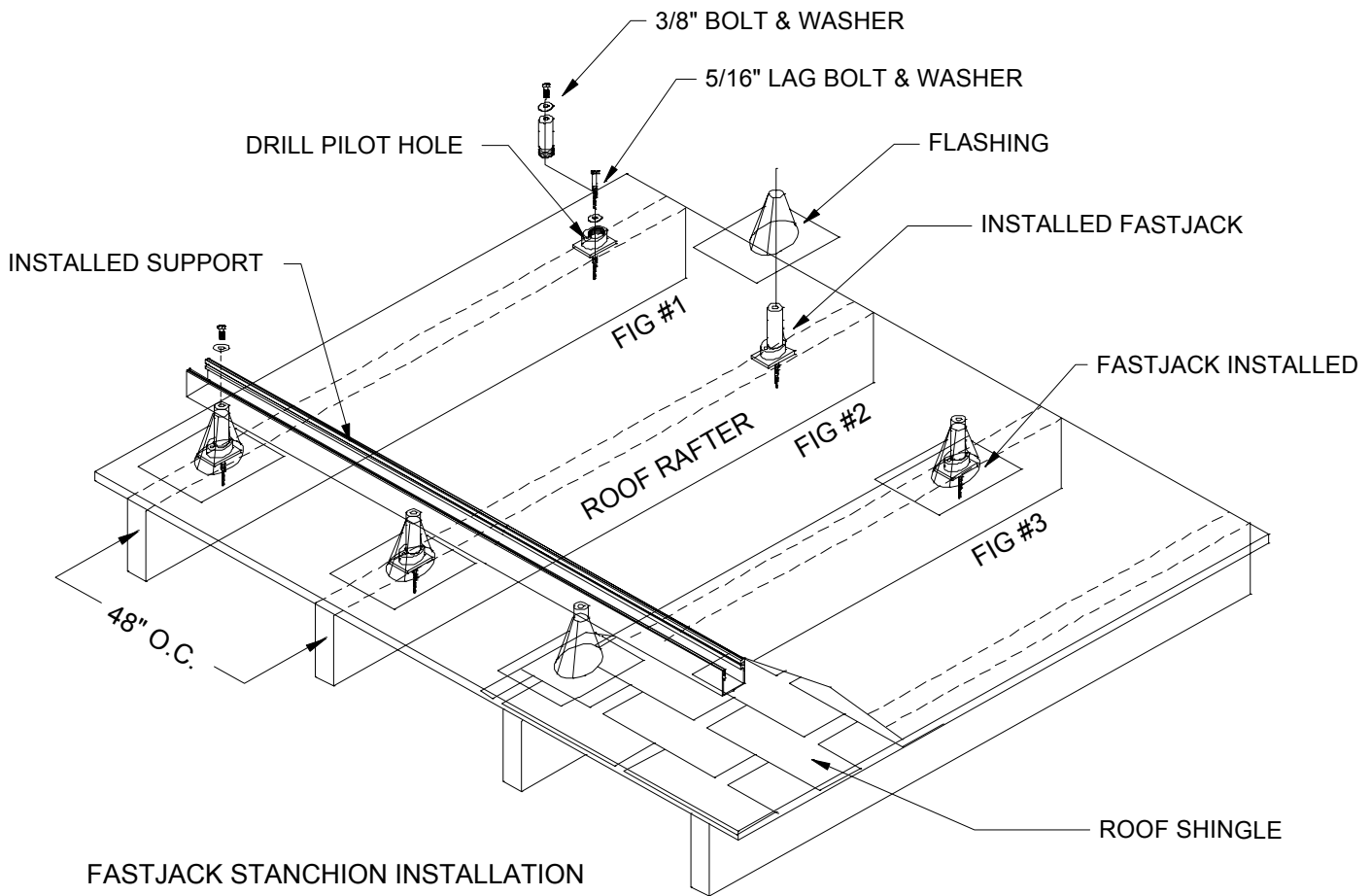

FASTJACK STANCHION INSTALLATION

## Installation of the **FASTJACK®** support rails to the attachment feet.

The illustration above shows how the FastJack™ flashable mount is installed on a new roof. (see the following page for more detailed installation instructions). The same spans apply to the **FASTJACK®** mount as with the **TILE TRAC®**, attachment feet. All attachments to the roof should be made at 48" rafter centers, and all rafters must be located and securely bolted into. There are four heights of **FASTJACK®** mounts and they range from 3", which is generally used for the Oatey® style neoprene (low profile) flashing, to 7-1/2". The 4-1/2" is recommended for mounting to the composition shingle roof using a standard metal roof flashing. The 6" and 7-1/2" sizes are for flat tile roofs and curve tile using double flashings. One feature of the

**FASTJACK®** is that the roofer can remove the posts for easy installation of the roof paper and later install them.

After the **FASTJACK®** mounts are installed, the support rails can be marked and installed in the same manner as illustrated on page 6 of the manual.

- Fig #1: **FASTJACK®** base is installed over the roof rafter and sheathing.
- Fig #2: Threaded post is screwed into the base and the flashing is installed over it.
- Fig # 3: Installed **FASTJACK®** ready for the roof covering.

*Caution: Always use care when walking around protruding stanchions.*

# INSTALLATION OF THE FASTJACK® FLASHABLE ROOF STANCHION

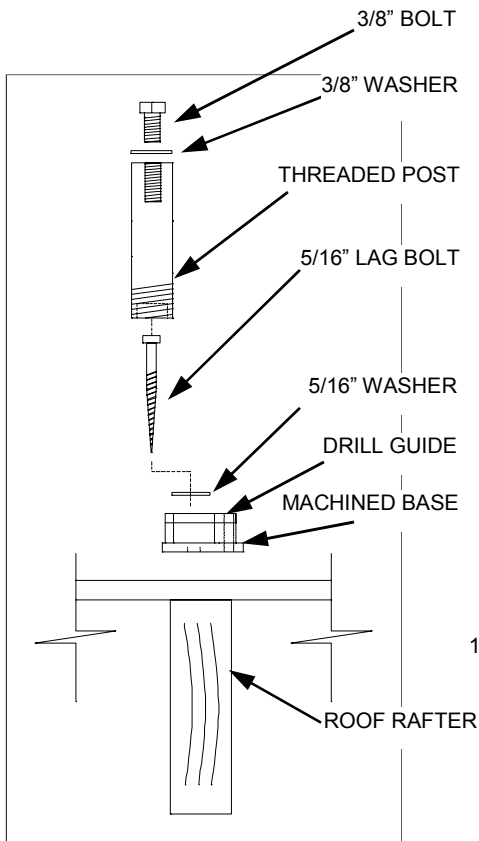

**FASTJACK™ INSTALLED PARTS DIAGRAM**

**FASTJACK®** flashable mount system includes a machined aluminum base with integrated drill guide, 1" aluminum threaded post and stainless steel hardware. The FJ Series patented (pat #6,360,491) design is engineered to provide structural attachment of modules when conventional roof flashings are required. FJ mounts are available in two sizes; the 4-1/4" FJ-425 (for conventional metal flashings) and the 3" FJ-300 for Oatey® style (low profile) neoprene flashings. The FJ design allows all flashings to install flat on the roof decking. FJ's superior strength while using only one single lag bolt (included) results from having the bolt installed directly under the support post. The system has been laboratory tested to 1,200 pounds and along with it's integrated drill guide insures perfect connections every time.

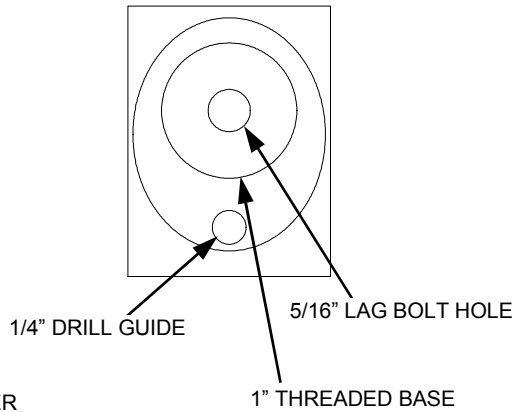

**REQUIRED TOOLS:**  
1/4" DRILL BIT AND POWER DRILL  
1/2" SOCKET  
1" PIPE PLIERS

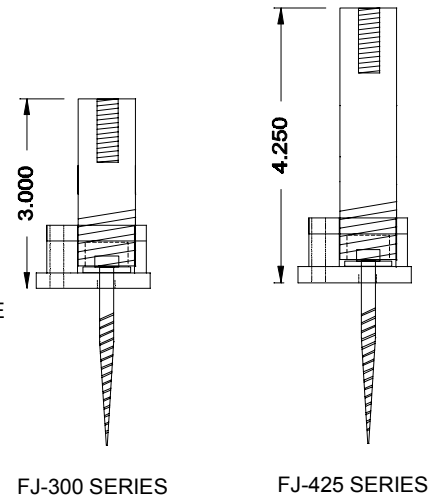

FJ-300 SERIES

FJ-425 SERIES

**DRILLING THE PILOT HOLE**  
Place the mount base of the over the location of the rafter. Align the 1/4" (drill guide) over the rafter center. While holding the base—insert the bit through the guide and drill down approx 1" into the roof.

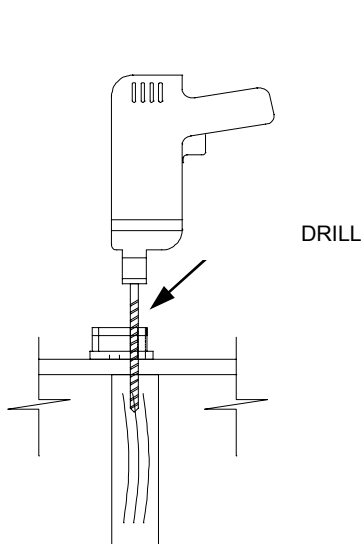

DRILL

**BOLTING INTO THE RAFTER**  
Place the 5/16" lag bolt thru the washer and AF base. Insert the lag bolt into the pilot hole made in the roof. Drive the lag bolt into the rafter using a 1/2" socket and impact wrench.

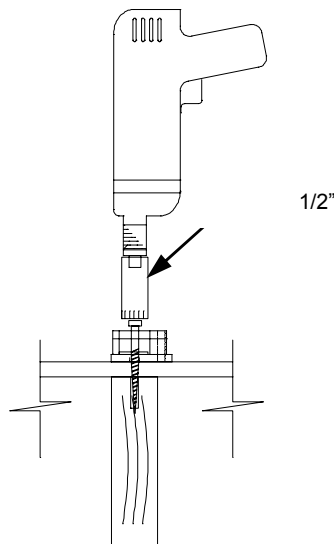

1/2"

**INSTALLING THE POST SUPPORT**  
Screw the threaded post into the base and tighten with a pipe pliers. Install the flashing over the post and attach the module support using the 3/8" bolt and washer (included).

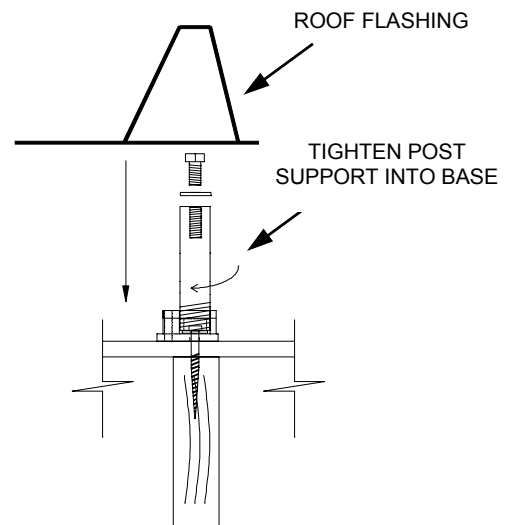

TIGHTEN POST SUPPORT INTO BASE

# INSTALLATION OF TILE TRAC®

**STEP 1**

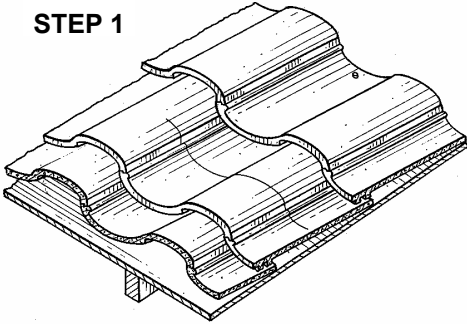

**STEP 1:** MARK A REFERENCE LINE ACROSS THE TILES IN THE VICINITY OF THE ROOF RAFTER. REMOVE THE ROOF TILE BY PUSHING AND PULLING ON THE TILE: IT IS HELD IN PLACE BY A SMALL NAIL. LIFT WITH A FLAT NAIL BAR IF NECESSARY.

**STEP 2**

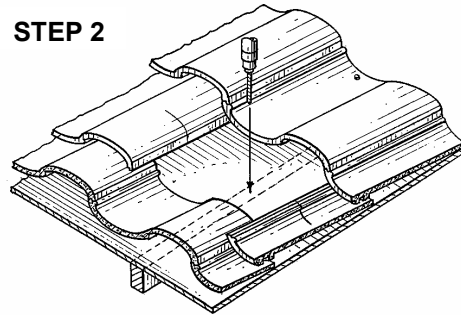

**STEP 2:** LOCATE THE CENTER OF THE RAFTER BY TAPPING WITH A HAMMER OR USING AN ELECTRONIC STUD SENSOR. AFTER LOCATING THE CENTER OF THE RAFTER DRILL A 3/16" PILOT HOLE IN LINE WITH THE CHALK LINE.

**STEP 3**

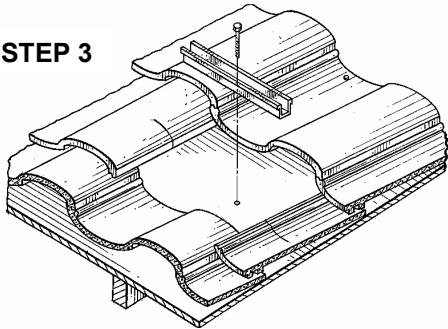

**STEP 3:** INSTALL THE LOWER TRACK ASSEMBLY USING A 5/16" LAG BOLT AND SPECIAL WASHER. PLACE SEALANT AROUND BOLT AND LOWER TRACK, BE SURE TO SEAL THE NAIL HOLE FROM THE TILE YOU REMOVED.

**STEP 4**

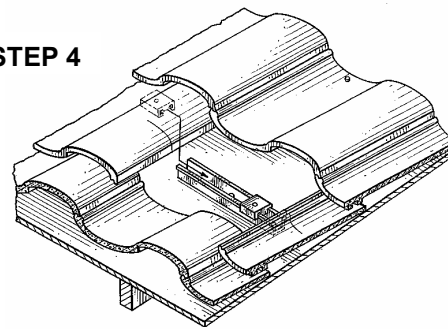

**STEP 4:** AFTER INSTALLING THE LOWER TRACK, SLIDE THE UPPER MOVABLE CARRIAGE ASSEMBLY INTO POSITION AT THE HIGH POINT OF THE TILE.

**STEP 5**

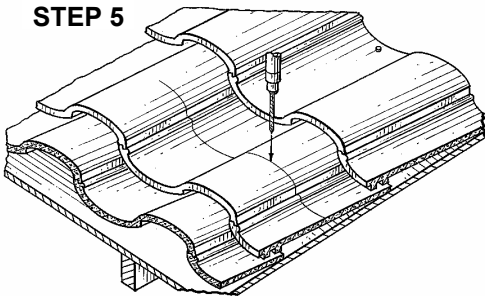

**STEP 5:** REPLACE THE TILE AND DRILL A 3/8" HOLE USING A MASONRY DRILL, INTERSECTING THE REFERENCE LINE AND THE HIGH POINT OF THE TILE.

**STEP 6**

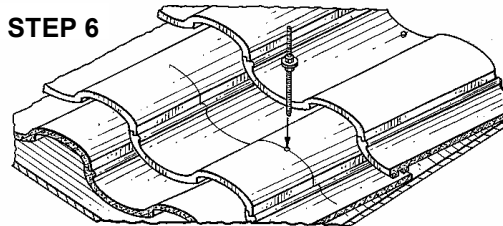

**STEP 6:** INSERT THE THREADED SHAFT THROUGH THE HOLE IN THE ROOF TILE, LOCATING THE UPPER **TILE TRAC®** CARRIAGE. IF NECESSARY, PICK UP THE ROOF TILE TO ASSIST IN STARTING THE THREADED SHAFT. INSERT AND LOCK TWO 3/8" NUTS ON THE THREADED SHAFT AND TIGHTEN DOWN USING A 9/16" WRENCH.

**STEP 7**

**BIND TWO 3/8" NUTS TOGETHER**

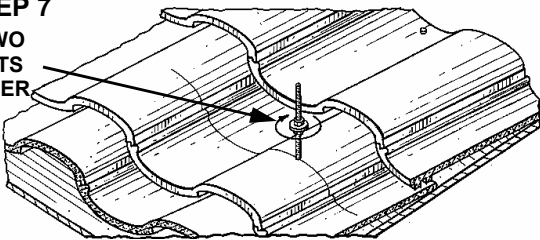

**STEP 7:** INSERT AND LOCK TWO 3/8" NUTS ON THE THREADED SHAFT AND TIGHTEN DOWN USING A 9/16" WRENCH.

**STEP 8**

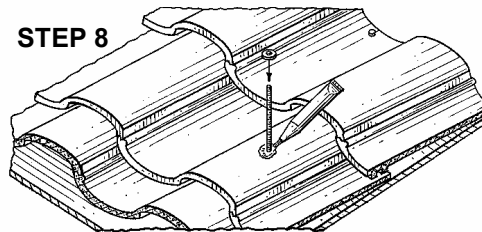

**STEP 8:** APPLY SEALANT AROUND THE THREADED SHAFT COMPRESSING THE SEALANT WITH THE ENCLOSED 3/8" WASHER.

**REFER TO PAGE SIX FOR INSTALLATION OF THE SUPPORT RAIL.**

# SPLICE KIT INSTRUCTIONS:

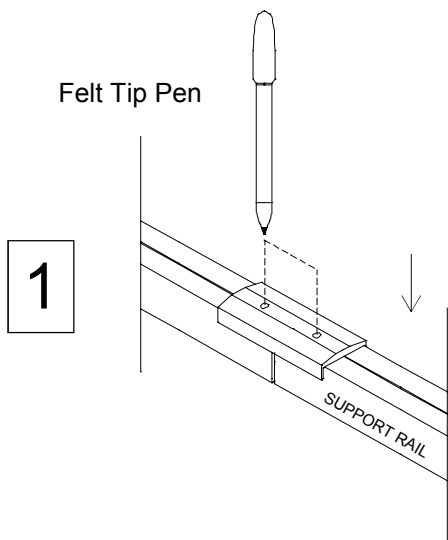

Turn the support rails so the bottom is facing up. Place the lower splice extrusion over the rails to use as a template. Center the lower splice extrusion over the rails and mark using a small felt pen.

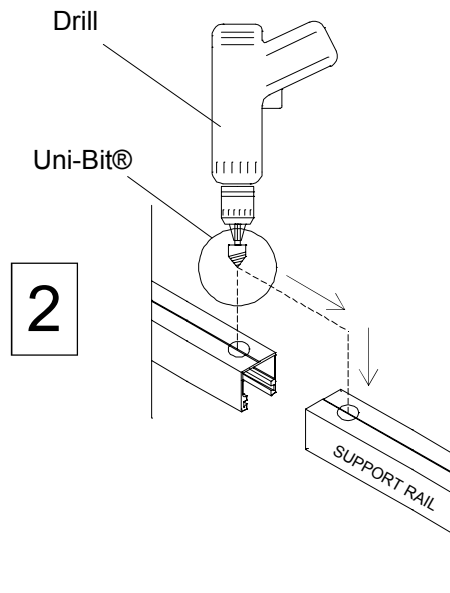

Drill two holes using a 1/2" #10 "Uni-Bit"® - drill at the intersection of the reference mark and the extruded "V" groove in the lower support assembly.

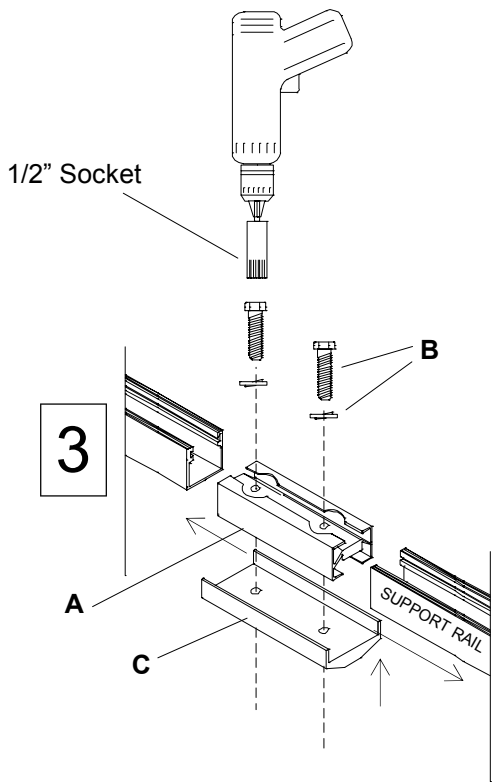

Insert the splice "A" into the channel and install "B" —the two 5/16" bolts / lock washers— into the lower support "C". Tighten using a 1/2" socket. Splice insert is designed to expand into the extrusion walls forcing the rails into alignment, do not over tighten. Roof Trac™ support rails can now be handled and installed as one solid rail.

## Splice Expansion Feature:

Roof Trac™ splice kits are designed to hold support rails in alignment for convenient installation. It allows for thermal expansion (side movement) of the aluminum after attachment. To use this feature; assemble the sections together allowing a 3/16" gap between sections. After installing the supports remove one of the 5/16" bolts. Thermal expansion of the aluminum support rails will now be absorbed in the splice connection instead of stressing the roof attachments. The remaining splice kit bolt and assembly will keep the support rails in perfect alignment.