

NOTES: UNLESS OTHERWISE SPECIFIED

1. SEE DRAWING NO. CB-00303 AND PROCEDURE P-1000 FOR ASSEMBLY AND TEST INSTRUCTION. PROCEDURES AND ASSEMBLY DRAWINGS ARE FOR INTERNAL USE ONLY.
2. ALL TESTING ARE IAW BATTERY COUNCIL INTERNATIONAL STANDARDS.
3. ALL DIMENSIONS ARE IN INCHES [MM].

REVISIONS			
REV	DESCRIPTION	DATE	APPROVED
B	ADDED TERMINAL OPTIONS ADDED NOTES, REV TITLE	3/28/00	DG

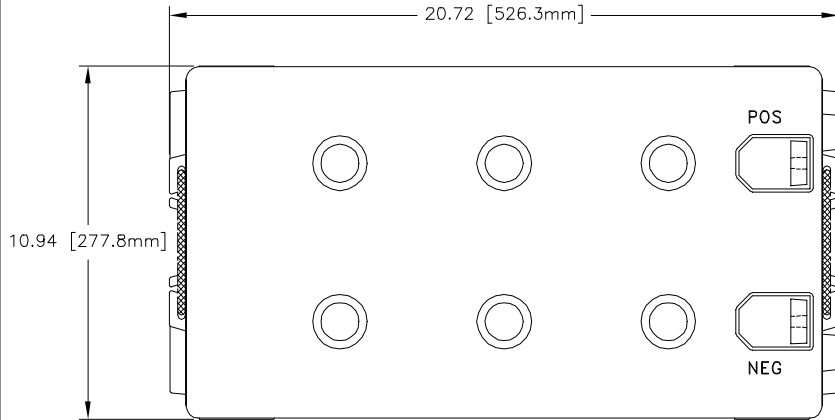

PVX-12255 TERMINAL OPTIONS

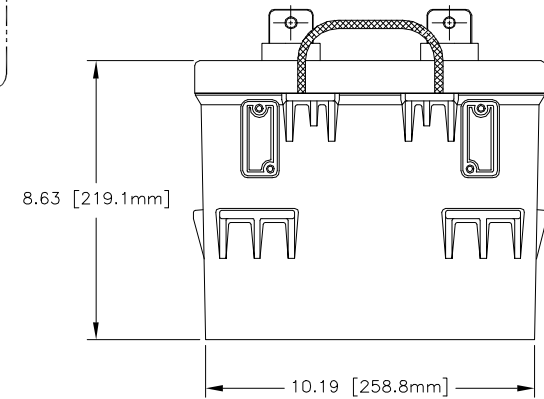
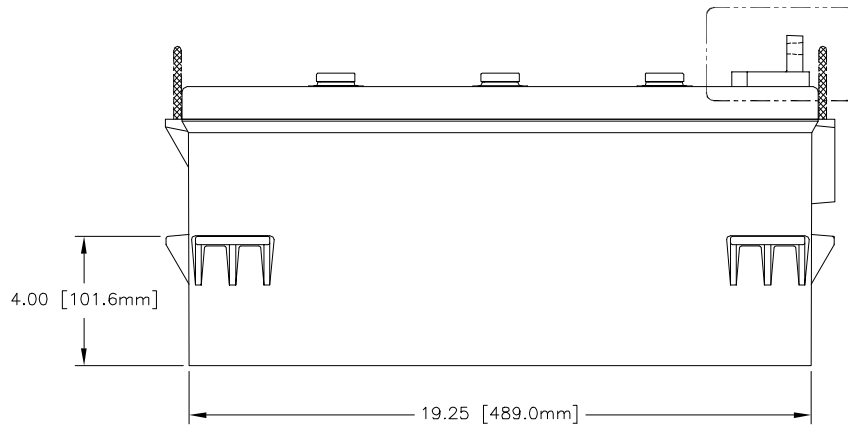
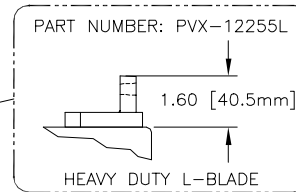

CAPACITY RATINGS	
PART NUMBER	PVX-12255
NOMINAL WEIGHT	162 LBS[73.6 KG]
AMPERE HOUR CAPACITY @ 20 HOUR 1.75 VOLTS/CELL @ 77°F (25° C)	255 AH
MINUTES OF DISCHARGE @ 25 AMPS 1.75 VOLTS/CELL @ 77°F (25° C)	475 MIN

ENVELOPE DRAWING

QTY REQD	CAGE CODE	PART OR IDENTIFYING NO.	NOMENCLATURE OR DESCRIPTION	MATERIAL SPECIFICATION	ITEM NO.
PARTS LIST					
UNLESS OTHERWISE SPECIFIED DIMENSIONS ARE IN INCHES TOLERANCES ARE:			CONCORDE BATTERY CORPORATION		
FRACTIONS DECIMALS ANGLES			2009 SAN BERNARDINO RD, W. COVINA, CA 91790		
.XX ± .12			TITLE		
.XXX ± .060			BATTERY, 12 VOLT, PVX-12255		
TREATMENT		CONTRACT NO.		SIZE CAGE CODE DWG NO.	
NONE		APPROVALS DATE		C 63017 PVX-12255	
FINISH		DRAWN PRECIADO M. 1/7/98		REV B	
NONE		CHECKED AMIII 2/5/98		REV B	
SIMILAR TO		APPROVED JBT 2/16/98		REV B	
N/A		ISSUED DR 3/28/00		REV B	
ACT WT N/A		SCALE NONE		SHEET 1 OF 1	
DLC WT N/A		SCALE NONE		SHEET 1 OF 1	